

Usulan Perbaikan Fasilitas Kerja pada Produksi Parutan Kelapa Berdasarkan Hasil Evaluasi QEC dan REBA

Irvan Cahya Laksana¹⁾, Handy Febri Satoto²⁾

Universitas 17 Agustus 1945 Surabaya, Jl. Semolowaru No. 45, Menur Pumpungan, Kec. Sukolilo, Kota SBY, Jawa Timur 60118,

Email ; irvancahya2000@gmail.com¹⁾, handyfebri@untag-sby.ac.id²⁾

Abstrak

Semakin berkembangnya suatu industri, maka perusahaan tentunya ingin agar produktivitas kerja bisa lebih baik dan akan meningkatkan produksi. Dengan adanya tenaga kerja yang kurang maksimal saat bekerja akan sangat mempengaruhi produktivitas itu sendiri. UD Bintang Timur ini didirikan pada tahun 1988 – sekarang yang terletak di Desa Palem Watu, Rt 03, Rw 02, Gempol Kurung, Kec. Menganti, Kab. Gresik. UD Bintang Timur memproduksi alat produksi berupa Mesin Parut Kelapa, Mesin Cabut Bulu Ayam, dan Mesin Perontok Padi. Peralatan produksi di UD Bintang Timur ada Mesin Bubut, Bor Duduk, Las, Pengecatan, Gerenda Tangan, Gerenda Duduk, Pemotong Almini, Dan Gerenda Duduk Penghalusan. Saat ini para pekerja di UD Bintang masih bekerja dengan fasilitas dan postur yang kurang nyaman saat bekerja. Maka dari itu tujuan peneliti membuat rancangan perbaikan fasilitas kerja dengan berdasarkan hasil evaluasi dengan menggunakan metode QEC dan REBA. Metode postur kerja Quick Exposure Check (QEC) dan Rapid Entry Body Assessment (REBA) dipakai untuk menganalisa keluhan musculoskeletal dan mengutamakan kondisi para pekerja dari dua sisi, yaitu sisi peneliti (observer) dan dari sisi para pekerja itu sendiri, sehingga dapat memperkecil subjektifitas yang ada.

Kata kunci : Perancangan Fasilitas, QEC, REBA, Produktivitas.

Abstract

The more developed an industry, the company certainly wants work productivity to be better and will increase production. With a workforce that is less than optimal at work will greatly affect the productivity itself. UD Bintang Timur was established in 1988 – now it is located in Palem Watu Village, Rt 03, Rw 02, Gempol Kurung, Menganti, Gresik. UD Bintang Timur produces production equipment in the form of Grated Coconut Machines, Chicken Feather Removal Machines, and Rice Thresher Machines. Production equipment at UD Bintang Timur includes Lathes, Drill Bits, Welding, Painting, Hand Mills, Seated Grinders, Almini Cutters, and Grinding Benches. Currently, workers at UD Bintang are still working with uncomfortable facilities and postures while working. Therefore the aim of the researchers is to design a work facility improvement plan based on the evaluation results using the QEC and REBA methods. The Quick Exposure Check (QEC) and Rapid Entry Body Assessment (REBA) work posture methods are used to further analyze musculoskeletal complaints and also take more into account the conditions experienced by workers from two points of view, namely from the observer's point of view and from the observer's point of view. point of view of the workers themselves, so as to minimize the existing subjectivity.

Keyword : Facility Design, QEC, REBA, Productivity

I. PENDAHULUAN

Semakin berkembangnya suatu industri, maka perusahaan tentunya ingin agar produktivitas kerja bisalebih baik dan akan meningkatkan produksi. Dengan adanya tenaga kerja yang kurang maksimal saat bekerja akan sangat mempengaruhi produktivitas itu sendiri. Banyak faktor yang mempengaruhi suatu produktivitas salah satunya adalah postur kerja para tenaga kerja. Salah satu yang membisa mempengaruhi Produktivitas seorang tenaga kerja adalah kondisi stasiun kerja di tempat operator tersebut bekerja. Kondisi tidak baiknya stasiun kerja dapat menurunkan performansi operator, hal itu disebabkan karena tenaga kerja yang melakukan pekerjaan namun tidak sesuai postur kerjanya dan akan menimbulkan suatu resiko cedera dalam jangka waktu tertentu.

Seseorang tenaga kerja melakukan pergerakan mengulang-ulang dan terus menerus dengan postur kerja yang tidak tepat serta dengan kekuatan yang berlebihan akan menimbulkan resiko cedera otot rangka/sistem musculoskeletal (musculoskeletal disorder). Dan dari hasil amatan yang dilakukan oleh peneliti, maka ditemukan masalah yakni kurang tepatnya postur kerja para tenaga kerja ini dalam melakukan suatu pekerjaan yang nantinya akan menumbulkan suatu masalah, yakni cedera.

Berikut merupakan tabel data para pekerja dan keluhan bagian tubuh pekerja :

Tabel 1 Data dan Keluhan Pekerja

Usulan Perbaikan Fasilitas Kerja pada Produksi Parutan Kelapa Berdasarkan...

Nama	Umur (Tahun)	Stasiun Kerja	Bagian tubuh yang dikeluhkan
Heru	39	Mesin Bor	Punggung dan leher
Minto	43	Alat Pemotong manual	Punggung, leher, bahu, paha, dan betis
Muhajir	43	Mesin Pemotong otomatis	Tidak ada keluhan
Samsul	29	Mesin bubut	Tidak ada keluhan
Supriyanto	42	Pengelasan	Punggung, leher, dan lengan kanan
		Perakitan	
Rifa'i	29	Pengecatan	Tidak ada keluhan

Dari tabel diatas, dapat ditemukan suatu permasalahan yakni pada stasiun kerja mesin bor, alat pemotong manual, dan pengelasan. Pada proses tersebut diprioritaskan karena pada lapangan ditemukan keluhan dari para operator yakni beberapa gangguan pada beberapa bagian tubuh para pekerja. Sedangkan pada proses selain yang disebutkan tadi tidak menjadi prioritas utama perbaikan karena pada dasarnya di proses tersebut tidak ada keluhan yang terjadi pada para pekerjanya dikarenakan sudah ada fasilitas kerja yang sesuai dengan kebutuhannya.

Tujuan dari penelitian ini adalah untuk menganalisa penilaian postur kerja dengan metode Quick Exposure Checklist (QEC) dan Rapid Entire Body Assesment (REBA) yang diperoleh pada data para pekerja yang ada di UD. Bintang Timur dan memberikan usulan rancangan fasilitas kerja pada UD. Bintang Timur agar nantinya dapat dipecahkan masalahnya dan meningkatkan produktivitas kerja.

II. PENELITIAN TERDAHULU

Penelitian terdahulu yang dilakukan oleh Annisa Purbasari, Maria Azista, Benedikta Anna H. Siboro (2019) dalam penelitiannya yang mempunyai judul "Analisis Postur Kerja Secara Ergonomi Pada Operator Pencetakan Pilar Yang Menimbulkan Risiko Musculoskeletal" peneliti terdahulu ini menggunakan metode Quick Exposure Checklist untuk pengukuran nilai resiko dari musculoskeletal.[7]

Pada penelitian terdahulunya jika dibandingkan dengan penelitian sekarang terletak pada metode yang dipakai. Pada penelitian terdahulu metode yang dipakai hanya menggunakan metode Quick Exposure Checklist yang tentunya masih menimbulkan kesubjektifitasan yang tinggi. Pada penelitian ini ditambahkan lagi satu metode yang dapat mengurangi subjektifitas dan bisa menilai dari 2 sudut pandang yang berbeda, yaitu ditambahkan metode Rapid Entire Body Assesment.

III. MATERI DAN METODE

Ergonomi

Menurut [6] Asosiasi Ergonomi Internasional menjelaskan bahwa ergonomi berawal dari kata *ergon* dan *nomos* yang memiliki arti kerja dan hukum alam keda kata tersebut berasal dari bahasa Yunani dan bisa diartikan sebagai studi yang terdiri dari beberapa aspek lingkungan kerja manusia yang dapat dilihat dari segi anatomi, fisiologi, psikologi, engineering, manajemen, desain atau perancangan.

Berat Beban Kerja

Suatu masalah yang terdapat pada bagian produksi sangat berkaitan dengan kondisi postur kerja dan harus melakukan pekerjaan tersebut secara berulang dan dengan satu jenis otot. Pekerjaan pada produksi terlebih operator mesin memerlukan gerakan postur kerja yang sesuai dan konsentrasi yang tinggi. Perubahan gerakan terjadi dengan cepat tergantung oleh posisi dan intensitas pengulangan pergerakan untuk waktu yang lama bisa menimbulkan rasa kurang nyaman pada tubuh pekerja.

Postur dan Pergerakan Kerja

a. Postur Kerja

Postur kerja adalah suatu sikap yang dilakukan saat bekerja. Kondisi sikap bekerja yang tidak sesuai juga akan membuat kekuatan yang dihasilkan juga berbeda. Pada kondisi bekerja seharusnya dilakukan dengan alamiah agar bisa mengurangi timbulnya cedera. Bekerja menjadi nyaman jika pekerja melakukan pekerjaan dengan postur kerja yang nyaman dan baik. Postur para pekerja yang baik sangat ditentukan oleh gerak dari organ tubuh yang dipakai bekerja [8].

b. Frekuensi

Kondisi postur kerja yang tidak sesuai dan intensitas pekerjaan yang tinggi bisa menyebabkan kurangnya suplai darah, inflamasi dan tekanan pada otot tubuh, frekuensi terjadinya postur yang kurang tepat dengan terjadinya repetitive motion dalam bekerja. Otot mengalami keluhan disebabkan oleh tekanan akibat beban kerja yang mengulang dan tidak mengalami relaksasi (Bridger, 2003).[3]

c. Force atau Beban

Force adalah suatu usaha yang dilakukan untuk melakukan gerakan. Suatu pekerjaan yang mengharuskan menggunakan tenaga besar, maka akan dapat memberikan beban besar pula pada otot, ligament, tendon, dan juga sendi. Objek adalah faktor yang bisa mempengaruhi terjadi gangguan pada otot rangka. Beban maksimal yang bisa dilakukan oleh seseorang yaitu 23kg – 25kg. Ukuran dan bentuk dari objek juga bisa mempengaruhi.

Musculoskeletal Disorder

Menurut [4] musculoskeletal disorder adalah suatu kondisi yang bisa mempengaruhi fungsi dari jaringan halus sistem termasuk syaraf, otot, tendon dan juga penunjang lain.

Quick Exposure Checklist (QEC)

Quick Exposure Check [2] merupakan suatu metode penilaian terhadap resiko yang ada pada pekerjaan yang bisa menambah nilai WMSDs (Work-Related Musculoskeletal Disorders), seperti gerakan yang berulang, berat beban kerja, kurang nyamannya postur kerja, dan juga intensitas pekerjaan. Dengan menggunakan metode QEC bisa memadukan antara penilaian dari sisi peneliti dan dari sisi operator. Penilaian ini bisa didapat dari besar atau tidaknya resiko pada punggung, bahu/lengan, tangan dan pergelangan serta leher yang nantinya ada hubungannya dengan suatu pekerjaan, dan memperlihatkan apakah intervensi ergonomi terbukti efektif (dengan naik turunnya skor).

Rapid Entire Body Assessment (REBA)

[1] mengemukakan metode REBA secara cepat dapat menilai resiko tubuh bagian tubuh atas. Metode REBA relatif mudah digunakan karena untuk mengetahui nilai suatu postur tubuh tidak diperlukan besar sudut yang spesifik, hanya berupa range sudut.

The diagram illustrates the REBA (Rapid Entire Body Assessment) scoring process, divided into two main sections: A. Neck, Trunk and Leg Analysis, and B. Arm and Wrist Analysis. It includes various tables (A, B, C) for scoring different body parts based on posture and force, and a final activity score calculation.

A. Neck, Trunk and Leg Analysis

Step 1: Locate Neck Position

10-20° +1, 20°+ +2, 20°+ in extension +2

Step 1a: Adjust...
If neck is twisted: +1
If neck is side bending: +1

Neck Score

Table A		Neck											
		1				2				3			
Legs		1	2	3	4	1	2	3	4	1	2	3	4
Trunk		1	1	2	3	4	1	2	3	4	3	3	5
Posture		2	2	3	4	5	3	4	5	6	4	5	6
Score		3	2	4	5	6	4	5	6	7	5	6	7
		4	3	5	6	7	5	6	7	8	6	7	8
		5	4	6	7	8	6	7	8	9	7	8	9

Step 2: Locate Trunk Position

7° +1, 0-30° +2, 30-60° +3, 60°+ +4

Step 2a: Adjust...
If trunk is twisted: +1
If trunk is side bending: +1

Trunk Score

Table B		Lower Arm					
		1			2		
Wrist		1	2	3	1	2	3
Upper Arm		1	1	2	1	2	3
		2	1	2	3	2	3
		3	3	4	5	4	5
		4	4	5	5	6	7
		5	6	7	8	7	8
		6	7	8	8	9	9

Step 3: Legs

Adjust: 30-60° +1, >60° +2

Leg Score

Table C		Score B											
Score A		1	2	3	4	5	6	7	8	9	10	11	12
1		1	1	1	2	3	3	4	5	6	7	7	7
2		1	2	2	3	4	4	5	6	6	7	7	8
3		2	3	3	3	4	5	6	7	7	8	8	8
4		3	4	4	4	5	6	7	8	8	9	9	9
5		4	4	4	5	6	7	8	8	9	9	9	9
6		6	6	6	7	8	8	9	9	10	10	10	10
7		7	7	7	8	9	9	9	10	10	11	11	11
8		8	8	8	9	10	10	10	10	11	11	11	11
9		9	9	9	10	10	10	11	11	11	12	12	12
10		10	10	10	11	11	11	11	12	12	12	12	12
11		11	11	11	11	12	12	12	12	12	12	12	12
12		12	12	12	12	12	12	12	12	12	12	12	12

Step 4: Look-up Posture Score in Table A

Using values from steps 1-3 above, Locate score in Table A

Posture Score A

Step 5: Add Force/Load Score

If load < 11 lbs.: +0
If load 11 to 22 lbs.: +1
If load > 22 lbs.: +2
Adjust: If shock or rapid build up of force: add +1

Force / Load Score

Step 6: Score A, Find Row in Table C

Add values from steps 4 & 5 to obtain Score A. Find Row in Table C.

Score A

Scoring

1 = Negligible Risk
2-3 = Low Risk. Change may be needed.
4-7 = Medium Risk. Further Investigate. Change Soon.
8-10 = High Risk. Investigate and Implement Change
11+ = Very High Risk. Implement Change

B. Arm and Wrist Analysis

Step 7: Locate Upper Arm Position:

20° +1, 20°+ +2, 20°+ +2, 20-45° +3, 90°+ +4

Step 7a: Adjust...
If shoulder is raised: +1
If upper arm is abducted: +1
If arm is supported or person is leaning: -1

Upper Arm Score

Step 8: Locate Lower Arm Position:

+1, +2

Lower Arm Score

Step 9: Locate Wrist Position:

15° +1, 15°+ +2

Wrist Score

Step 9a: Adjust...
If wrist is bent from midline or twisted: Add +1

Step 10: Look-up Posture Score in Table B

Using values from steps 7-9 above, locate score in Table B

Posture Score B

Step 11: Add Coupling Score

Well fitting Handle and mid rang power grip, good: +0
Acceptable but not ideal hand hold or coupling acceptable with another body part, fair: +1
Hand hold not acceptable but possible, poor: +2
No handles, awkward, unsafe with any body part, Unacceptable: +3

Coupling Score

Step 12: Score B, Find Column in Table C

Add values from steps 10 & 11 to obtain Score B. Find column in Table C and match with Score A in row from step 6 to obtain Table C Score.

Score B

Step 13: Activity Score

+1 1 or more body parts are held for longer than 1 minute (static)
+1 Repeated small range actions (more than 4x per minute)
+1 Action causes rapid large range changes in postures or unstable base

Table C Score + Activity Score = REBA Score

Gambar 1 Modul Pengukuran Skor REBA

Usulan Perbaikan Fasilitas Kerja pada Produksi Parutan Kelapa Berdasarkan...

Antropometri

Menurut Antropometri dapat diartikan secara jelas yaitu merupakan suatu ilmu yang berkaitan secara khusus menyangkut dimensi tubuh manusia (Norfiza and Zul, 2011).[5]

Percentil

Persentil adalah suatu nilai yang menyatakan bahwa persentase tertentu dari sekelompok orang yang dimensinya sama atau lebih rendah dari nilai tersebut (Nurmianto, 2004).[6]

Perhitungan persentil dilakukan bertujuan agar bisa mendapatkan ukuran toleransi, sehingga alat yang nantinya dibuat bisa fleksible digunakan siapapun.

Tabel 2 Rumus Percentil

Persentil	Perhitungan
1%	$\bar{x} - 2.325\sigma$
2.5%	$\bar{x} - 1.960\sigma$
5%	$\bar{x} - 1.645\sigma$
10%	$\bar{x} - 1.280\sigma$
50%	\bar{x}
90%	$\bar{x} + 1.280\sigma$
95%	$\bar{x} + 1.645\sigma$
97.5%	$\bar{x} + 1.960\sigma$
99%	$\bar{x} + 2.325\sigma$

Metode

Berikut merupakan flowchart penelitian penilaian postur kerja dengan menggunakan metode Quick Exposure Check (QEC) pada UD.Bintang Timur

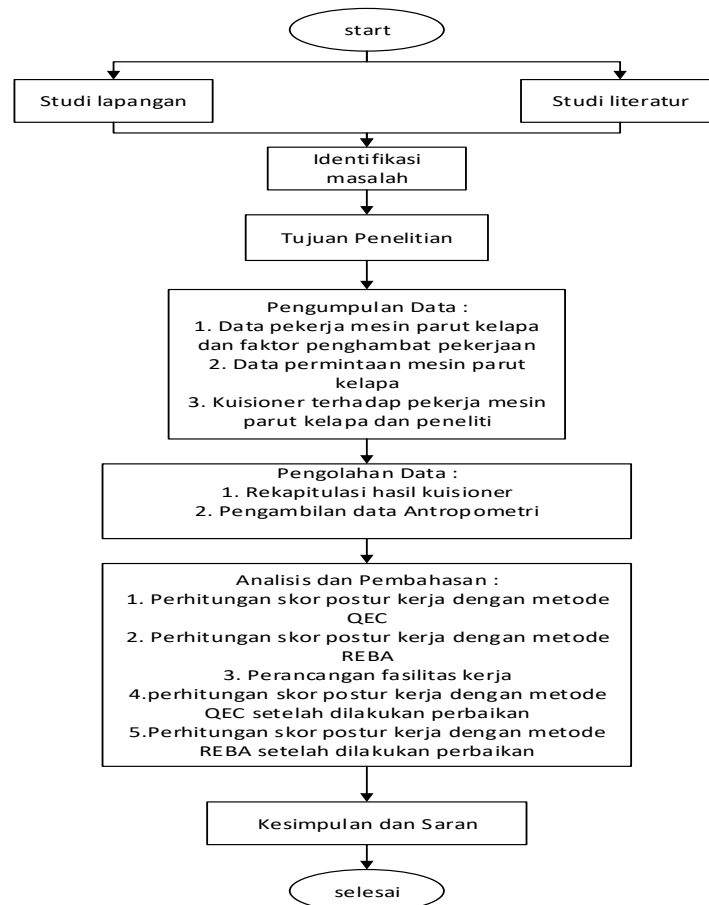

Gambar 2 Flowchart

Dari gambar flowchart diatas bisa diketahui proses atau tahapan dalam menyelesaikan permasalahan dari tahap awal hingga tahap akhir. Berikut tahapan analisis dan pembahasan data :

1. Perhitungan skor postur kerja dengan QEC (awal)
2. Perhitungan skor postur kerja dengan REBA (awal)
3. Perancangan fasilitas kerja
4. Perhitungan skor postur kerja dengan QEC (akhir)
5. Perhitungan skor postur kerja dengan REBA (Akhir)

Dari hasil analisa dan pembahasan terseut bisa diketahui dan dibandingkan sebelum dan sesudah dilakukan perbaikan.

IV. HASIL DAN PEMBAHASAN

1. Kuisisioner QEC Awal

Tabel 3 Rekapitulasi Kuisisioner Pengamat

Stasiun kerja	Punggung		Lengan/bahu		Pergelangan Tangan		leher
	1	2	1	2	1	2	
Mesin bor	A2	B4	C3	D3	E2	F2	G3
pemotong manual	A3	B4	C2	D3	E2	F1	G3
Potong otomatis	A1	B2	C1	D3	E1	F2	G1
Mesin bubut	A1	B2	C1	D1	E1	F1	G1
Pengelasan	A3	B4	C2	D3	E2	F2	G3
Perakitan	A2	B2	C1	D2	E2	F1	G2
pengecatan	A1	B1	C2	D2	E1	F1	G1

Pada tabel diatas merupakan rekapitulasi dari jawaban yang ada pada kuisisioner yang dilakukan oleh pengamat.

Tabel 4 Rekapitulasi Kuisisioner Operator

Stasiun kerja	pertanyaan							
	H	I	J	K	L	M	N	O
Mesin bor	H2	I1	J4	K3	L1	M2	N3	O2
Pemotong manual	H2	I1	J4	K3	L1	M2	N1	O3
Potong otomatis	H1	I1	J2	K2	L1	M2	N2	O1
Mesin bubut	H1	I1	J2	K2	L1	M2	N1	O1
Pengelasan	H2	I2	J4	K3	L2	M2	N1	O2
Perakitan	H1	I1	J2	K2	L1	M1	N1	O1
Pengecatan	H1	I1	J2	K2	L1	M2	N1	O1

Pada tabel diatas merupakan rekapitulasi dari jawaban dari kuisisioner operator.

a. Operator Mesin Bor

Hasil rekapitulasi kuisisioner adalah sebagai berikut :

Usulan Perbaikan Fasilitas Kerja pada Produksi Parutan Kelapa Berdasarkan...

EXPOSURE SCORE	NAMA PEKERJA: Heru	TANGGAL :	PEKERJAAN :Mesin Bor																																																																																																																																																																																																																																																																																																																																																																																																																																															
Punggung Posisi Punggung A & Beban H <table border="1" style="width: 100%; border-collapse: collapse;"> <tr><th></th><th>A1</th><th>A2</th><th>A3</th></tr> <tr><td>H1</td><td>2</td><td>4</td><td>6</td></tr> <tr><td>H2</td><td>4</td><td>6</td><td>8</td></tr> <tr><td>H3</td><td>6</td><td>8</td><td>10</td></tr> <tr><td>H4</td><td>8</td><td>10</td><td>12</td></tr> <tr><td>Score 1</td><td colspan="3" style="text-align: center;">6</td></tr> </table> Posisi Punggung A & Durasi I <table border="1" style="width: 100%; border-collapse: collapse;"> <tr><th></th><th>A1</th><th>A2</th><th>A3</th></tr> <tr><td>I1</td><td>2</td><td>4</td><td>6</td></tr> <tr><td>I2</td><td>4</td><td>6</td><td>8</td></tr> <tr><td>I3</td><td>6</td><td>8</td><td>10</td></tr> <tr><td>Score 2</td><td colspan="3" style="text-align: center;">4</td></tr> </table> Posisi Durasi I & Beban H <table border="1" style="width: 100%; border-collapse: collapse;"> <tr><th></th><th>I1</th><th>I2</th><th>I3</th></tr> <tr><td>H1</td><td>2</td><td>4</td><td>6</td></tr> <tr><td>H2</td><td>4</td><td>6</td><td>8</td></tr> <tr><td>H3</td><td>6</td><td>8</td><td>10</td></tr> <tr><td>H4</td><td>8</td><td>10</td><td>12</td></tr> <tr><td>Score 3</td><td colspan="3" style="text-align: center;">4</td></tr> </table> <p>Untuk pekerjaan statis gunakan skoring 4 Untuk material handling gunakan skoring 5 dan 6</p> Posisi Statis B & Durasi I <table border="1" style="width: 100%; border-collapse: collapse;"> <tr><th></th><th>B1</th><th>B2</th></tr> <tr><td>I1</td><td>2</td><td>4</td></tr> <tr><td>I2</td><td>4</td><td>6</td></tr> <tr><td>I3</td><td>6</td><td>8</td></tr> <tr><td>Score 4</td><td colspan="2" style="text-align: center;">6</td></tr> </table> Frekuensi B & Beban H <table border="1" style="width: 100%; border-collapse: collapse;"> <tr><th></th><th>B3</th><th>B4</th><th>B5</th></tr> <tr><td>H1</td><td>2</td><td>4</td><td>6</td></tr> <tr><td>H2</td><td>4</td><td>6</td><td>8</td></tr> <tr><td>H3</td><td>6</td><td>8</td><td>10</td></tr> <tr><td>H4</td><td>8</td><td>10</td><td>12</td></tr> <tr><td>Score 5</td><td colspan="3" style="text-align: center;">6</td></tr> </table> Frekuensi B & durasi I <table border="1" style="width: 100%; border-collapse: collapse;"> <tr><th></th><th>B3</th><th>B4</th><th>B5</th></tr> <tr><td>I1</td><td>2</td><td>4</td><td>6</td></tr> <tr><td>I2</td><td>4</td><td>6</td><td>8</td></tr> <tr><td>I3</td><td>6</td><td>8</td><td>10</td></tr> <tr><td>Score 6</td><td colspan="3" style="text-align: center;">4</td></tr> </table> <p>Total skor punggung = total skor 1 sampai 4 atau total skor 1 sampai 3 ditambah 5&6</p> <div style="border: 1px solid black; width: 100%; text-align: center;">24</div>		A1	A2	A3	H1	2	4	6	H2	4	6	8	H3	6	8	10	H4	8	10	12	Score 1	6				A1	A2	A3	I1	2	4	6	I2	4	6	8	I3	6	8	10	Score 2	4				I1	I2	I3	H1	2	4	6	H2	4	6	8	H3	6	8	10	H4	8	10	12	Score 3	4				B1	B2	I1	2	4	I2	4	6	I3	6	8	Score 4	6			B3	B4	B5	H1	2	4	6	H2	4	6	8	H3	6	8	10	H4	8	10	12	Score 5	6				B3	B4	B5	I1	2	4	6	I2	4	6	8	I3	6	8	10	Score 6	4			Bahu/Lengan Tinggi C & Beban H <table border="1" style="width: 100%; border-collapse: collapse;"> <tr><th></th><th>C1</th><th>C2</th><th>C3</th></tr> <tr><td>H1</td><td>2</td><td>4</td><td>6</td></tr> <tr><td>H2</td><td>4</td><td>6</td><td>8</td></tr> <tr><td>H3</td><td>6</td><td>8</td><td>10</td></tr> <tr><td>H4</td><td>8</td><td>10</td><td>12</td></tr> <tr><td>Score 1</td><td colspan="3" style="text-align: center;">8</td></tr> </table> Tinggi C & Durasi I <table border="1" style="width: 100%; border-collapse: collapse;"> <tr><th></th><th>C1</th><th>C2</th><th>C3</th></tr> <tr><td>I1</td><td>2</td><td>4</td><td>6</td></tr> <tr><td>I2</td><td>4</td><td>6</td><td>8</td></tr> <tr><td>I3</td><td>6</td><td>8</td><td>10</td></tr> <tr><td>Score 2</td><td colspan="3" style="text-align: center;">6</td></tr> </table> Durasi I & Beban H <table border="1" style="width: 100%; border-collapse: collapse;"> <tr><th></th><th>I1</th><th>I2</th><th>I3</th></tr> <tr><td>H1</td><td>2</td><td>4</td><td>6</td></tr> <tr><td>H2</td><td>4</td><td>6</td><td>8</td></tr> <tr><td>H3</td><td>6</td><td>8</td><td>10</td></tr> <tr><td>H4</td><td>8</td><td>10</td><td>12</td></tr> <tr><td>Score 3</td><td colspan="3" style="text-align: center;">4</td></tr> </table> Frekuensi D & Beban H <table border="1" style="width: 100%; border-collapse: collapse;"> <tr><th></th><th>D1</th><th>D2</th><th>D3</th></tr> <tr><td>H1</td><td>2</td><td>4</td><td>6</td></tr> <tr><td>H2</td><td>4</td><td>6</td><td>8</td></tr> <tr><td>H3</td><td>6</td><td>8</td><td>10</td></tr> <tr><td>H4</td><td>8</td><td>10</td><td>12</td></tr> <tr><td>Score 4</td><td colspan="3" style="text-align: center;">8</td></tr> </table> Frekuensi B & durasi I <table border="1" style="width: 100%; border-collapse: collapse;"> <tr><th></th><th>D1</th><th>D2</th><th>D3</th></tr> <tr><td>I1</td><td>2</td><td>4</td><td>6</td></tr> <tr><td>I2</td><td>4</td><td>6</td><td>8</td></tr> <tr><td>I3</td><td>6</td><td>8</td><td>10</td></tr> <tr><td>Score 5</td><td colspan="3" style="text-align: center;">6</td></tr> </table> <p>Total skor bahu/lengan = total skor 1 sampai 5</p> <div style="border: 1px solid black; width: 100%; text-align: center;">32</div>		C1	C2	C3	H1	2	4	6	H2	4	6	8	H3	6	8	10	H4	8	10	12	Score 1	8				C1	C2	C3	I1	2	4	6	I2	4	6	8	I3	6	8	10	Score 2	6				I1	I2	I3	H1	2	4	6	H2	4	6	8	H3	6	8	10	H4	8	10	12	Score 3	4				D1	D2	D3	H1	2	4	6	H2	4	6	8	H3	6	8	10	H4	8	10	12	Score 4	8				D1	D2	D3	I1	2	4	6	I2	4	6	8	I3	6	8	10	Score 5	6			Pergelangan tangan Gerakan Berulang F & Kekuatan J <table border="1" style="width: 100%; border-collapse: collapse;"> <tr><th></th><th>F1</th><th>F2</th><th>F3</th></tr> <tr><td>J1</td><td>2</td><td>4</td><td>6</td></tr> <tr><td>J2</td><td>4</td><td>6</td><td>8</td></tr> <tr><td>J3</td><td>6</td><td>8</td><td>10</td></tr> <tr><td>J4</td><td>8</td><td>10</td><td>12</td></tr> <tr><td>Score 1</td><td colspan="3" style="text-align: center;">10</td></tr> </table> Gerakan Berulang F & Durasi I <table border="1" style="width: 100%; border-collapse: collapse;"> <tr><th></th><th>F1</th><th>F2</th><th>F3</th></tr> <tr><td>I1</td><td>2</td><td>4</td><td>6</td></tr> <tr><td>I2</td><td>4</td><td>6</td><td>8</td></tr> <tr><td>I3</td><td>6</td><td>8</td><td>10</td></tr> <tr><td>Score 2</td><td colspan="3" style="text-align: center;">4</td></tr> </table> Durasi I & Kekuatan J <table border="1" style="width: 100%; border-collapse: collapse;"> <tr><th></th><th>I1</th><th>I2</th><th>I3</th></tr> <tr><td>J1</td><td>2</td><td>4</td><td>6</td></tr> <tr><td>J2</td><td>4</td><td>6</td><td>8</td></tr> <tr><td>J3</td><td>6</td><td>8</td><td>10</td></tr> <tr><td>J4</td><td>8</td><td>10</td><td>12</td></tr> <tr><td>Score 3</td><td colspan="3" style="text-align: center;">8</td></tr> </table> Posisi pergelangan tangan E & Kekuatan J <table border="1" style="width: 100%; border-collapse: collapse;"> <tr><th></th><th>E1</th><th>E2</th></tr> <tr><td>J1</td><td>2</td><td>4</td></tr> <tr><td>J2</td><td>4</td><td>6</td></tr> <tr><td>J3</td><td>6</td><td>8</td></tr> <tr><td>J4</td><td>8</td><td>10</td></tr> <tr><td>Score 4</td><td colspan="2" style="text-align: center;">10</td></tr> </table> Posisi pergelangan tangan E & durasi I <table border="1" style="width: 100%; border-collapse: collapse;"> <tr><th></th><th>E1</th><th>E2</th></tr> <tr><td>I1</td><td>2</td><td>4</td></tr> <tr><td>I2</td><td>4</td><td>6</td></tr> <tr><td>I3</td><td>6</td><td>8</td></tr> <tr><td>Score 5</td><td colspan="2" style="text-align: center;">4</td></tr> </table> <p>Total skor pergelangan tangan = total skor 1 sampai 5</p> <div style="border: 1px solid black; width: 100%; text-align: center;">36</div>		F1	F2	F3	J1	2	4	6	J2	4	6	8	J3	6	8	10	J4	8	10	12	Score 1	10				F1	F2	F3	I1	2	4	6	I2	4	6	8	I3	6	8	10	Score 2	4				I1	I2	I3	J1	2	4	6	J2	4	6	8	J3	6	8	10	J4	8	10	12	Score 3	8				E1	E2	J1	2	4	J2	4	6	J3	6	8	J4	8	10	Score 4	10			E1	E2	I1	2	4	I2	4	6	I3	6	8	Score 5	4		leher Posisi Leher G & Durasi I <table border="1" style="width: 100%; border-collapse: collapse;"> <tr><th></th><th>G1</th><th>G2</th><th>G3</th></tr> <tr><td>I1</td><td>2</td><td>4</td><td>6</td></tr> <tr><td>I2</td><td>4</td><td>6</td><td>8</td></tr> <tr><td>I3</td><td>6</td><td>8</td><td>10</td></tr> <tr><td>Score 1</td><td colspan="3" style="text-align: center;">6</td></tr> </table> Kebutuhan Visual K & Durasi I <table border="1" style="width: 100%; border-collapse: collapse;"> <tr><th></th><th>K1</th><th>K2</th><th>K3</th></tr> <tr><td>I1</td><td>2</td><td>4</td><td>6</td></tr> <tr><td>I2</td><td>4</td><td>6</td><td>8</td></tr> <tr><td>I3</td><td>6</td><td>8</td><td>10</td></tr> <tr><td>Score 2</td><td colspan="3" style="text-align: center;">6</td></tr> </table> <p>Total skor pergelangan tangan = total skor 1 sampai 2</p> <div style="border: 1px solid black; width: 100%; text-align: center;">12</div> Dasar Kestabilan <table border="1" style="width: 100%; border-collapse: collapse;"> <tr><th></th><th>L1</th><th>L2</th><th>L3</th></tr> <tr><td>K1</td><td>2</td><td>4</td><td>6</td></tr> <tr><td>Total Kestabilan</td><td colspan="3" style="text-align: center;">1</td></tr> </table> Proses Bekerja <table border="1" style="width: 100%; border-collapse: collapse;"> <tr><th></th><th>M1</th><th>M2</th><th>M3</th></tr> <tr><td>B1</td><td>2</td><td>4</td><td>6</td></tr> <tr><td>Total Proses Bekerja</td><td colspan="3" style="text-align: center;">4</td></tr> </table> Proses Getaran <table border="1" style="width: 100%; border-collapse: collapse;"> <tr><th></th><th>N1</th><th>N2</th><th>N3</th></tr> <tr><td>G1</td><td>2</td><td>4</td><td>6</td></tr> <tr><td>Total Getaran</td><td colspan="3" style="text-align: center;">9</td></tr> </table> Stress Kerja Akibat Keluhan <table border="1" style="width: 100%; border-collapse: collapse;"> <tr><th></th><th>O1</th><th>O2</th><th>O3</th><th>O4</th></tr> <tr><td>K1</td><td>2</td><td>4</td><td>6</td><td>8</td></tr> <tr><td>Total stress kerja</td><td colspan="4" style="text-align: center;">4</td></tr> </table>		G1	G2	G3	I1	2	4	6	I2	4	6	8	I3	6	8	10	Score 1	6				K1	K2	K3	I1	2	4	6	I2	4	6	8	I3	6	8	10	Score 2	6				L1	L2	L3	K1	2	4	6	Total Kestabilan	1				M1	M2	M3	B1	2	4	6	Total Proses Bekerja	4				N1	N2	N3	G1	2	4	6	Total Getaran	9				O1	O2	O3	O4	K1	2	4	6	8	Total stress kerja	4			
	A1	A2	A3																																																																																																																																																																																																																																																																																																																																																																																																																																															
H1	2	4	6																																																																																																																																																																																																																																																																																																																																																																																																																																															
H2	4	6	8																																																																																																																																																																																																																																																																																																																																																																																																																																															
H3	6	8	10																																																																																																																																																																																																																																																																																																																																																																																																																																															
H4	8	10	12																																																																																																																																																																																																																																																																																																																																																																																																																																															
Score 1	6																																																																																																																																																																																																																																																																																																																																																																																																																																																	
	A1	A2	A3																																																																																																																																																																																																																																																																																																																																																																																																																																															
I1	2	4	6																																																																																																																																																																																																																																																																																																																																																																																																																																															
I2	4	6	8																																																																																																																																																																																																																																																																																																																																																																																																																																															
I3	6	8	10																																																																																																																																																																																																																																																																																																																																																																																																																																															
Score 2	4																																																																																																																																																																																																																																																																																																																																																																																																																																																	
	I1	I2	I3																																																																																																																																																																																																																																																																																																																																																																																																																																															
H1	2	4	6																																																																																																																																																																																																																																																																																																																																																																																																																																															
H2	4	6	8																																																																																																																																																																																																																																																																																																																																																																																																																																															
H3	6	8	10																																																																																																																																																																																																																																																																																																																																																																																																																																															
H4	8	10	12																																																																																																																																																																																																																																																																																																																																																																																																																																															
Score 3	4																																																																																																																																																																																																																																																																																																																																																																																																																																																	
	B1	B2																																																																																																																																																																																																																																																																																																																																																																																																																																																
I1	2	4																																																																																																																																																																																																																																																																																																																																																																																																																																																
I2	4	6																																																																																																																																																																																																																																																																																																																																																																																																																																																
I3	6	8																																																																																																																																																																																																																																																																																																																																																																																																																																																
Score 4	6																																																																																																																																																																																																																																																																																																																																																																																																																																																	
	B3	B4	B5																																																																																																																																																																																																																																																																																																																																																																																																																																															
H1	2	4	6																																																																																																																																																																																																																																																																																																																																																																																																																																															
H2	4	6	8																																																																																																																																																																																																																																																																																																																																																																																																																																															
H3	6	8	10																																																																																																																																																																																																																																																																																																																																																																																																																																															
H4	8	10	12																																																																																																																																																																																																																																																																																																																																																																																																																																															
Score 5	6																																																																																																																																																																																																																																																																																																																																																																																																																																																	
	B3	B4	B5																																																																																																																																																																																																																																																																																																																																																																																																																																															
I1	2	4	6																																																																																																																																																																																																																																																																																																																																																																																																																																															
I2	4	6	8																																																																																																																																																																																																																																																																																																																																																																																																																																															
I3	6	8	10																																																																																																																																																																																																																																																																																																																																																																																																																																															
Score 6	4																																																																																																																																																																																																																																																																																																																																																																																																																																																	
	C1	C2	C3																																																																																																																																																																																																																																																																																																																																																																																																																																															
H1	2	4	6																																																																																																																																																																																																																																																																																																																																																																																																																																															
H2	4	6	8																																																																																																																																																																																																																																																																																																																																																																																																																																															
H3	6	8	10																																																																																																																																																																																																																																																																																																																																																																																																																																															
H4	8	10	12																																																																																																																																																																																																																																																																																																																																																																																																																																															
Score 1	8																																																																																																																																																																																																																																																																																																																																																																																																																																																	
	C1	C2	C3																																																																																																																																																																																																																																																																																																																																																																																																																																															
I1	2	4	6																																																																																																																																																																																																																																																																																																																																																																																																																																															
I2	4	6	8																																																																																																																																																																																																																																																																																																																																																																																																																																															
I3	6	8	10																																																																																																																																																																																																																																																																																																																																																																																																																																															
Score 2	6																																																																																																																																																																																																																																																																																																																																																																																																																																																	
	I1	I2	I3																																																																																																																																																																																																																																																																																																																																																																																																																																															
H1	2	4	6																																																																																																																																																																																																																																																																																																																																																																																																																																															
H2	4	6	8																																																																																																																																																																																																																																																																																																																																																																																																																																															
H3	6	8	10																																																																																																																																																																																																																																																																																																																																																																																																																																															
H4	8	10	12																																																																																																																																																																																																																																																																																																																																																																																																																																															
Score 3	4																																																																																																																																																																																																																																																																																																																																																																																																																																																	
	D1	D2	D3																																																																																																																																																																																																																																																																																																																																																																																																																																															
H1	2	4	6																																																																																																																																																																																																																																																																																																																																																																																																																																															
H2	4	6	8																																																																																																																																																																																																																																																																																																																																																																																																																																															
H3	6	8	10																																																																																																																																																																																																																																																																																																																																																																																																																																															
H4	8	10	12																																																																																																																																																																																																																																																																																																																																																																																																																																															
Score 4	8																																																																																																																																																																																																																																																																																																																																																																																																																																																	
	D1	D2	D3																																																																																																																																																																																																																																																																																																																																																																																																																																															
I1	2	4	6																																																																																																																																																																																																																																																																																																																																																																																																																																															
I2	4	6	8																																																																																																																																																																																																																																																																																																																																																																																																																																															
I3	6	8	10																																																																																																																																																																																																																																																																																																																																																																																																																																															
Score 5	6																																																																																																																																																																																																																																																																																																																																																																																																																																																	
	F1	F2	F3																																																																																																																																																																																																																																																																																																																																																																																																																																															
J1	2	4	6																																																																																																																																																																																																																																																																																																																																																																																																																																															
J2	4	6	8																																																																																																																																																																																																																																																																																																																																																																																																																																															
J3	6	8	10																																																																																																																																																																																																																																																																																																																																																																																																																																															
J4	8	10	12																																																																																																																																																																																																																																																																																																																																																																																																																																															
Score 1	10																																																																																																																																																																																																																																																																																																																																																																																																																																																	
	F1	F2	F3																																																																																																																																																																																																																																																																																																																																																																																																																																															
I1	2	4	6																																																																																																																																																																																																																																																																																																																																																																																																																																															
I2	4	6	8																																																																																																																																																																																																																																																																																																																																																																																																																																															
I3	6	8	10																																																																																																																																																																																																																																																																																																																																																																																																																																															
Score 2	4																																																																																																																																																																																																																																																																																																																																																																																																																																																	
	I1	I2	I3																																																																																																																																																																																																																																																																																																																																																																																																																																															
J1	2	4	6																																																																																																																																																																																																																																																																																																																																																																																																																																															
J2	4	6	8																																																																																																																																																																																																																																																																																																																																																																																																																																															
J3	6	8	10																																																																																																																																																																																																																																																																																																																																																																																																																																															
J4	8	10	12																																																																																																																																																																																																																																																																																																																																																																																																																																															
Score 3	8																																																																																																																																																																																																																																																																																																																																																																																																																																																	
	E1	E2																																																																																																																																																																																																																																																																																																																																																																																																																																																
J1	2	4																																																																																																																																																																																																																																																																																																																																																																																																																																																
J2	4	6																																																																																																																																																																																																																																																																																																																																																																																																																																																
J3	6	8																																																																																																																																																																																																																																																																																																																																																																																																																																																
J4	8	10																																																																																																																																																																																																																																																																																																																																																																																																																																																
Score 4	10																																																																																																																																																																																																																																																																																																																																																																																																																																																	
	E1	E2																																																																																																																																																																																																																																																																																																																																																																																																																																																
I1	2	4																																																																																																																																																																																																																																																																																																																																																																																																																																																
I2	4	6																																																																																																																																																																																																																																																																																																																																																																																																																																																
I3	6	8																																																																																																																																																																																																																																																																																																																																																																																																																																																
Score 5	4																																																																																																																																																																																																																																																																																																																																																																																																																																																	
	G1	G2	G3																																																																																																																																																																																																																																																																																																																																																																																																																																															
I1	2	4	6																																																																																																																																																																																																																																																																																																																																																																																																																																															
I2	4	6	8																																																																																																																																																																																																																																																																																																																																																																																																																																															
I3	6	8	10																																																																																																																																																																																																																																																																																																																																																																																																																																															
Score 1	6																																																																																																																																																																																																																																																																																																																																																																																																																																																	
	K1	K2	K3																																																																																																																																																																																																																																																																																																																																																																																																																																															
I1	2	4	6																																																																																																																																																																																																																																																																																																																																																																																																																																															
I2	4	6	8																																																																																																																																																																																																																																																																																																																																																																																																																																															
I3	6	8	10																																																																																																																																																																																																																																																																																																																																																																																																																																															
Score 2	6																																																																																																																																																																																																																																																																																																																																																																																																																																																	
	L1	L2	L3																																																																																																																																																																																																																																																																																																																																																																																																																																															
K1	2	4	6																																																																																																																																																																																																																																																																																																																																																																																																																																															
Total Kestabilan	1																																																																																																																																																																																																																																																																																																																																																																																																																																																	
	M1	M2	M3																																																																																																																																																																																																																																																																																																																																																																																																																																															
B1	2	4	6																																																																																																																																																																																																																																																																																																																																																																																																																																															
Total Proses Bekerja	4																																																																																																																																																																																																																																																																																																																																																																																																																																																	
	N1	N2	N3																																																																																																																																																																																																																																																																																																																																																																																																																																															
G1	2	4	6																																																																																																																																																																																																																																																																																																																																																																																																																																															
Total Getaran	9																																																																																																																																																																																																																																																																																																																																																																																																																																																	
	O1	O2	O3	O4																																																																																																																																																																																																																																																																																																																																																																																																																																														
K1	2	4	6	8																																																																																																																																																																																																																																																																																																																																																																																																																																														
Total stress kerja	4																																																																																																																																																																																																																																																																																																																																																																																																																																																	

Gambar 3 Rekapitulasi Kuisisioner

Rekapitulasi kuisisioner pengamat dan rekapitulasi kuisisioner operator. Ditemukan bahwa pada bagian tubuh punggung mendapatkan skor 24, pada bagian tubuh bahu/lengan mendapatkan skor 32, pada bagian tubuh pergelangan tangan 36, pada bagian tubuh leher mendapatkan skor 12, pada dasar kestabilan beban kerja didapatkan skor 1, pada beban proses kerja mendapatkan nilai skor 4, pada beban proses getaran mendapatkan nilai 9, dan pada stress kerja akibat keluhan mendapatkan skor 4. Jika keseluruhan skor dijumlahkan maka mendapatkan skor 117. Setelah itu akan dihitung untuk mencari skor E.

$$E(\%) = \frac{X}{X_{max}} \times 100\% =$$

$$E(\%) = \frac{177}{176} \times 100\% = 66,47\%$$

Tabel 5 Kategori Skor QEC

QEC score (E)	Action
≤ 40%	Bisa Diterima
41-50%	Penyelidikan lebih lanjut
51-70%	Penyelidikan lebih lanjut dan dilakukan perbaikan segera
> 70%	Penyelidikan lebih lanjut dan dilakukan perbaikan sekarang juga

Pada tabel kategori diatas ditemukan bahwa pada proses mesin bor mendapatkan nilai 66,47%, nilai tersebut termasuk dalam kategori resiko tinggi dan perlu dilakukan perbaikan segera.

b. Operator Alat Potong Manual

EXPOSURE SCORE	NAMA PEKERJA: Minto	TANGGAL :	PEKERJAAN Potong Manual leher																																																																																																																																																																																																																																																																																																																																																																																																																																																																			
Panggung Poini Panggung A & Beban H <table border="1"> <tr><td></td><td>A1</td><td>A2</td><td>A3</td></tr> <tr><td>H1</td><td>2</td><td>4</td><td>6</td></tr> <tr><td>H2</td><td>4</td><td>6</td><td>8</td></tr> <tr><td>H3</td><td>6</td><td>8</td><td>10</td></tr> <tr><td>H4</td><td>8</td><td>10</td><td>12</td></tr> <tr><td>Score 1</td><td colspan="3">8</td></tr> </table> Poini Panggung A & Durasi I <table border="1"> <tr><td></td><td>A1</td><td>A2</td><td>A3</td></tr> <tr><td>I1</td><td>2</td><td>4</td><td>6</td></tr> <tr><td>I2</td><td>4</td><td>6</td><td>8</td></tr> <tr><td>I3</td><td>6</td><td>8</td><td>10</td></tr> <tr><td>I4</td><td>8</td><td>10</td><td>12</td></tr> <tr><td>Score 2</td><td colspan="3">6</td></tr> </table> Poini Durasi I & Beban H <table border="1"> <tr><td></td><td>I1</td><td>I2</td><td>I3</td></tr> <tr><td>H1</td><td>2</td><td>4</td><td>6</td></tr> <tr><td>H2</td><td>4</td><td>6</td><td>8</td></tr> <tr><td>H3</td><td>6</td><td>8</td><td>10</td></tr> <tr><td>H4</td><td>8</td><td>10</td><td>12</td></tr> <tr><td>Score 3</td><td colspan="3">4</td></tr> </table> Frekuensi B & Durasi I <table border="1"> <tr><td></td><td>B1</td><td>B2</td></tr> <tr><td>I1</td><td>2</td><td>4</td></tr> <tr><td>I2</td><td>4</td><td>6</td></tr> <tr><td>I3</td><td>6</td><td>8</td></tr> <tr><td>Score 4</td><td colspan="2">8</td></tr> </table> Frekuensi B & Beban H <table border="1"> <tr><td></td><td>B3</td><td>B4</td><td>B5</td></tr> <tr><td>H1</td><td>2</td><td>4</td><td>6</td></tr> <tr><td>H2</td><td>4</td><td>6</td><td>8</td></tr> <tr><td>H3</td><td>6</td><td>8</td><td>10</td></tr> <tr><td>H4</td><td>8</td><td>10</td><td>12</td></tr> <tr><td>Score 5</td><td colspan="3">6</td></tr> </table> Frekuensi B & durasi I <table border="1"> <tr><td></td><td>B3</td><td>B4</td><td>B5</td></tr> <tr><td>I1</td><td>2</td><td>4</td><td>6</td></tr> <tr><td>I2</td><td>4</td><td>6</td><td>8</td></tr> <tr><td>I3</td><td>6</td><td>8</td><td>10</td></tr> <tr><td>Score 6</td><td colspan="3">4</td></tr> </table> Total skor panggung = total skor 1 sampai 4 atau total skor 1 sampai 3 ditambah 5x6 28		A1	A2	A3	H1	2	4	6	H2	4	6	8	H3	6	8	10	H4	8	10	12	Score 1	8				A1	A2	A3	I1	2	4	6	I2	4	6	8	I3	6	8	10	I4	8	10	12	Score 2	6				I1	I2	I3	H1	2	4	6	H2	4	6	8	H3	6	8	10	H4	8	10	12	Score 3	4				B1	B2	I1	2	4	I2	4	6	I3	6	8	Score 4	8			B3	B4	B5	H1	2	4	6	H2	4	6	8	H3	6	8	10	H4	8	10	12	Score 5	6				B3	B4	B5	I1	2	4	6	I2	4	6	8	I3	6	8	10	Score 6	4			Bahu Lengan Tinggi C & Beban H <table border="1"> <tr><td></td><td>C1</td><td>C2</td><td>C3</td></tr> <tr><td>H1</td><td>2</td><td>4</td><td>6</td></tr> <tr><td>H2</td><td>4</td><td>6</td><td>8</td></tr> <tr><td>H3</td><td>6</td><td>8</td><td>10</td></tr> <tr><td>H4</td><td>8</td><td>10</td><td>12</td></tr> <tr><td>Score 1</td><td colspan="3">6</td></tr> </table> Tinggi C & Durasi I <table border="1"> <tr><td></td><td>C1</td><td>C2</td><td>C3</td></tr> <tr><td>I1</td><td>2</td><td>4</td><td>6</td></tr> <tr><td>I2</td><td>4</td><td>6</td><td>8</td></tr> <tr><td>I3</td><td>6</td><td>8</td><td>10</td></tr> <tr><td>I4</td><td>8</td><td>10</td><td>12</td></tr> <tr><td>Score 2</td><td colspan="3">4</td></tr> </table> Durasi I & Beban H <table border="1"> <tr><td></td><td>I1</td><td>I2</td><td>I3</td></tr> <tr><td>H1</td><td>2</td><td>4</td><td>6</td></tr> <tr><td>H2</td><td>4</td><td>6</td><td>8</td></tr> <tr><td>H3</td><td>6</td><td>8</td><td>10</td></tr> <tr><td>H4</td><td>8</td><td>10</td><td>12</td></tr> <tr><td>Score 3</td><td colspan="3">4</td></tr> </table> Frekuensi D & Beban H <table border="1"> <tr><td></td><td>D1</td><td>D2</td><td>D3</td></tr> <tr><td>H1</td><td>2</td><td>4</td><td>6</td></tr> <tr><td>H2</td><td>4</td><td>6</td><td>8</td></tr> <tr><td>H3</td><td>6</td><td>8</td><td>10</td></tr> <tr><td>H4</td><td>8</td><td>10</td><td>12</td></tr> <tr><td>Score 4</td><td colspan="3">8</td></tr> </table> Frekuensi D & durasi I <table border="1"> <tr><td></td><td>D1</td><td>D2</td><td>D3</td></tr> <tr><td>I1</td><td>2</td><td>4</td><td>6</td></tr> <tr><td>I2</td><td>4</td><td>6</td><td>8</td></tr> <tr><td>I3</td><td>6</td><td>8</td><td>10</td></tr> <tr><td>I4</td><td>8</td><td>10</td><td>12</td></tr> <tr><td>Score 5</td><td colspan="3">6</td></tr> </table> Total skor bahu/lengan = total skor 1 sampai 5 28		C1	C2	C3	H1	2	4	6	H2	4	6	8	H3	6	8	10	H4	8	10	12	Score 1	6				C1	C2	C3	I1	2	4	6	I2	4	6	8	I3	6	8	10	I4	8	10	12	Score 2	4				I1	I2	I3	H1	2	4	6	H2	4	6	8	H3	6	8	10	H4	8	10	12	Score 3	4				D1	D2	D3	H1	2	4	6	H2	4	6	8	H3	6	8	10	H4	8	10	12	Score 4	8				D1	D2	D3	I1	2	4	6	I2	4	6	8	I3	6	8	10	I4	8	10	12	Score 5	6			Pergelangan tangan Gerakan Berulang F & Kekuatan J <table border="1"> <tr><td></td><td>F1</td><td>F2</td><td>F3</td></tr> <tr><td>J1</td><td>2</td><td>4</td><td>6</td></tr> <tr><td>J2</td><td>4</td><td>6</td><td>8</td></tr> <tr><td>J3</td><td>6</td><td>8</td><td>10</td></tr> <tr><td>J4</td><td>8</td><td>10</td><td>12</td></tr> <tr><td>Score 1</td><td colspan="3">8</td></tr> </table> Gerakan Berulang F & Durasi I <table border="1"> <tr><td></td><td>F1</td><td>F2</td><td>F3</td></tr> <tr><td>I1</td><td>2</td><td>4</td><td>6</td></tr> <tr><td>I2</td><td>4</td><td>6</td><td>8</td></tr> <tr><td>I3</td><td>6</td><td>8</td><td>10</td></tr> <tr><td>I4</td><td>8</td><td>10</td><td>12</td></tr> <tr><td>Score 2</td><td colspan="3">2</td></tr> </table> Durasi I & Kekuatan J <table border="1"> <tr><td></td><td>I1</td><td>I2</td><td>I3</td></tr> <tr><td>J1</td><td>2</td><td>4</td><td>6</td></tr> <tr><td>J2</td><td>4</td><td>6</td><td>8</td></tr> <tr><td>J3</td><td>6</td><td>8</td><td>10</td></tr> <tr><td>J4</td><td>8</td><td>10</td><td>12</td></tr> <tr><td>Score 3</td><td colspan="3">8</td></tr> </table> Poini pergelangan tangan E & Kekuatan J <table border="1"> <tr><td></td><td>E1</td><td>E2</td></tr> <tr><td>J1</td><td>2</td><td>4</td></tr> <tr><td>J2</td><td>4</td><td>6</td></tr> <tr><td>J3</td><td>6</td><td>8</td></tr> <tr><td>J4</td><td>8</td><td>10</td></tr> <tr><td>Score 4</td><td colspan="2">10</td></tr> </table> Poini pergelangan tangan E & durasi I <table border="1"> <tr><td></td><td>E1</td><td>E2</td></tr> <tr><td>I1</td><td>2</td><td>4</td></tr> <tr><td>I2</td><td>4</td><td>6</td></tr> <tr><td>I3</td><td>6</td><td>8</td></tr> <tr><td>I4</td><td>8</td><td>10</td></tr> <tr><td>Score 5</td><td colspan="2">4</td></tr> </table> Total skor pergelangan tangan = total skor 1 sampai 5 32		F1	F2	F3	J1	2	4	6	J2	4	6	8	J3	6	8	10	J4	8	10	12	Score 1	8				F1	F2	F3	I1	2	4	6	I2	4	6	8	I3	6	8	10	I4	8	10	12	Score 2	2				I1	I2	I3	J1	2	4	6	J2	4	6	8	J3	6	8	10	J4	8	10	12	Score 3	8				E1	E2	J1	2	4	J2	4	6	J3	6	8	J4	8	10	Score 4	10			E1	E2	I1	2	4	I2	4	6	I3	6	8	I4	8	10	Score 5	4		Poini Leher G & Durasi I <table border="1"> <tr><td></td><td>G1</td><td>G2</td><td>G3</td></tr> <tr><td>I1</td><td>2</td><td>4</td><td>6</td></tr> <tr><td>I2</td><td>4</td><td>6</td><td>8</td></tr> <tr><td>I3</td><td>6</td><td>8</td><td>10</td></tr> <tr><td>Score 1</td><td colspan="3">6</td></tr> </table> Kebutuhan Visual K & Durasi I <table border="1"> <tr><td></td><td>K1</td><td>K2</td><td>K3</td></tr> <tr><td>I1</td><td>2</td><td>4</td><td>6</td></tr> <tr><td>I2</td><td>4</td><td>6</td><td>8</td></tr> <tr><td>I3</td><td>6</td><td>8</td><td>10</td></tr> <tr><td>Score 2</td><td colspan="3">6</td></tr> </table> Total skor pergelangan tangan = total skor 1 sampai 2 12		G1	G2	G3	I1	2	4	6	I2	4	6	8	I3	6	8	10	Score 1	6				K1	K2	K3	I1	2	4	6	I2	4	6	8	I3	6	8	10	Score 2	6			Dasar Kestabilan <table border="1"> <tr><td></td><td>L1</td><td>L2</td><td>L3</td></tr> <tr><td>K1</td><td>4</td><td>9</td><td></td></tr> <tr><td>Total Kestabilan</td><td colspan="3">1</td></tr> </table> Proses Bekerja <table border="1"> <tr><td></td><td>M1</td><td>M2</td><td>M3</td></tr> <tr><td>P1</td><td>4</td><td>9</td><td></td></tr> <tr><td>Total Proses Bekerja</td><td colspan="3">4</td></tr> </table> Getaran <table border="1"> <tr><td></td><td>N1</td><td>N2</td><td>N3</td></tr> <tr><td>G1</td><td>4</td><td>9</td><td></td></tr> <tr><td>Total Getaran</td><td colspan="3">1</td></tr> </table> Stress Kerja <table border="1"> <tr><td></td><td>O1</td><td>O2</td><td>O3</td><td>O4</td></tr> <tr><td>S1</td><td>4</td><td>9</td><td>16</td><td></td></tr> <tr><td>Total stress kerja</td><td colspan="4">9</td></tr> </table>		L1	L2	L3	K1	4	9		Total Kestabilan	1				M1	M2	M3	P1	4	9		Total Proses Bekerja	4				N1	N2	N3	G1	4	9		Total Getaran	1				O1	O2	O3	O4	S1	4	9	16		Total stress kerja	9			
	A1	A2	A3																																																																																																																																																																																																																																																																																																																																																																																																																																																																			
H1	2	4	6																																																																																																																																																																																																																																																																																																																																																																																																																																																																			
H2	4	6	8																																																																																																																																																																																																																																																																																																																																																																																																																																																																			
H3	6	8	10																																																																																																																																																																																																																																																																																																																																																																																																																																																																			
H4	8	10	12																																																																																																																																																																																																																																																																																																																																																																																																																																																																			
Score 1	8																																																																																																																																																																																																																																																																																																																																																																																																																																																																					
	A1	A2	A3																																																																																																																																																																																																																																																																																																																																																																																																																																																																			
I1	2	4	6																																																																																																																																																																																																																																																																																																																																																																																																																																																																			
I2	4	6	8																																																																																																																																																																																																																																																																																																																																																																																																																																																																			
I3	6	8	10																																																																																																																																																																																																																																																																																																																																																																																																																																																																			
I4	8	10	12																																																																																																																																																																																																																																																																																																																																																																																																																																																																			
Score 2	6																																																																																																																																																																																																																																																																																																																																																																																																																																																																					
	I1	I2	I3																																																																																																																																																																																																																																																																																																																																																																																																																																																																			
H1	2	4	6																																																																																																																																																																																																																																																																																																																																																																																																																																																																			
H2	4	6	8																																																																																																																																																																																																																																																																																																																																																																																																																																																																			
H3	6	8	10																																																																																																																																																																																																																																																																																																																																																																																																																																																																			
H4	8	10	12																																																																																																																																																																																																																																																																																																																																																																																																																																																																			
Score 3	4																																																																																																																																																																																																																																																																																																																																																																																																																																																																					
	B1	B2																																																																																																																																																																																																																																																																																																																																																																																																																																																																				
I1	2	4																																																																																																																																																																																																																																																																																																																																																																																																																																																																				
I2	4	6																																																																																																																																																																																																																																																																																																																																																																																																																																																																				
I3	6	8																																																																																																																																																																																																																																																																																																																																																																																																																																																																				
Score 4	8																																																																																																																																																																																																																																																																																																																																																																																																																																																																					
	B3	B4	B5																																																																																																																																																																																																																																																																																																																																																																																																																																																																			
H1	2	4	6																																																																																																																																																																																																																																																																																																																																																																																																																																																																			
H2	4	6	8																																																																																																																																																																																																																																																																																																																																																																																																																																																																			
H3	6	8	10																																																																																																																																																																																																																																																																																																																																																																																																																																																																			
H4	8	10	12																																																																																																																																																																																																																																																																																																																																																																																																																																																																			
Score 5	6																																																																																																																																																																																																																																																																																																																																																																																																																																																																					
	B3	B4	B5																																																																																																																																																																																																																																																																																																																																																																																																																																																																			
I1	2	4	6																																																																																																																																																																																																																																																																																																																																																																																																																																																																			
I2	4	6	8																																																																																																																																																																																																																																																																																																																																																																																																																																																																			
I3	6	8	10																																																																																																																																																																																																																																																																																																																																																																																																																																																																			
Score 6	4																																																																																																																																																																																																																																																																																																																																																																																																																																																																					
	C1	C2	C3																																																																																																																																																																																																																																																																																																																																																																																																																																																																			
H1	2	4	6																																																																																																																																																																																																																																																																																																																																																																																																																																																																			
H2	4	6	8																																																																																																																																																																																																																																																																																																																																																																																																																																																																			
H3	6	8	10																																																																																																																																																																																																																																																																																																																																																																																																																																																																			
H4	8	10	12																																																																																																																																																																																																																																																																																																																																																																																																																																																																			
Score 1	6																																																																																																																																																																																																																																																																																																																																																																																																																																																																					
	C1	C2	C3																																																																																																																																																																																																																																																																																																																																																																																																																																																																			
I1	2	4	6																																																																																																																																																																																																																																																																																																																																																																																																																																																																			
I2	4	6	8																																																																																																																																																																																																																																																																																																																																																																																																																																																																			
I3	6	8	10																																																																																																																																																																																																																																																																																																																																																																																																																																																																			
I4	8	10	12																																																																																																																																																																																																																																																																																																																																																																																																																																																																			
Score 2	4																																																																																																																																																																																																																																																																																																																																																																																																																																																																					
	I1	I2	I3																																																																																																																																																																																																																																																																																																																																																																																																																																																																			
H1	2	4	6																																																																																																																																																																																																																																																																																																																																																																																																																																																																			
H2	4	6	8																																																																																																																																																																																																																																																																																																																																																																																																																																																																			
H3	6	8	10																																																																																																																																																																																																																																																																																																																																																																																																																																																																			
H4	8	10	12																																																																																																																																																																																																																																																																																																																																																																																																																																																																			
Score 3	4																																																																																																																																																																																																																																																																																																																																																																																																																																																																					
	D1	D2	D3																																																																																																																																																																																																																																																																																																																																																																																																																																																																			
H1	2	4	6																																																																																																																																																																																																																																																																																																																																																																																																																																																																			
H2	4	6	8																																																																																																																																																																																																																																																																																																																																																																																																																																																																			
H3	6	8	10																																																																																																																																																																																																																																																																																																																																																																																																																																																																			
H4	8	10	12																																																																																																																																																																																																																																																																																																																																																																																																																																																																			
Score 4	8																																																																																																																																																																																																																																																																																																																																																																																																																																																																					
	D1	D2	D3																																																																																																																																																																																																																																																																																																																																																																																																																																																																			
I1	2	4	6																																																																																																																																																																																																																																																																																																																																																																																																																																																																			
I2	4	6	8																																																																																																																																																																																																																																																																																																																																																																																																																																																																			
I3	6	8	10																																																																																																																																																																																																																																																																																																																																																																																																																																																																			
I4	8	10	12																																																																																																																																																																																																																																																																																																																																																																																																																																																																			
Score 5	6																																																																																																																																																																																																																																																																																																																																																																																																																																																																					
	F1	F2	F3																																																																																																																																																																																																																																																																																																																																																																																																																																																																			
J1	2	4	6																																																																																																																																																																																																																																																																																																																																																																																																																																																																			
J2	4	6	8																																																																																																																																																																																																																																																																																																																																																																																																																																																																			
J3	6	8	10																																																																																																																																																																																																																																																																																																																																																																																																																																																																			
J4	8	10	12																																																																																																																																																																																																																																																																																																																																																																																																																																																																			
Score 1	8																																																																																																																																																																																																																																																																																																																																																																																																																																																																					
	F1	F2	F3																																																																																																																																																																																																																																																																																																																																																																																																																																																																			
I1	2	4	6																																																																																																																																																																																																																																																																																																																																																																																																																																																																			
I2	4	6	8																																																																																																																																																																																																																																																																																																																																																																																																																																																																			
I3	6	8	10																																																																																																																																																																																																																																																																																																																																																																																																																																																																			
I4	8	10	12																																																																																																																																																																																																																																																																																																																																																																																																																																																																			
Score 2	2																																																																																																																																																																																																																																																																																																																																																																																																																																																																					
	I1	I2	I3																																																																																																																																																																																																																																																																																																																																																																																																																																																																			
J1	2	4	6																																																																																																																																																																																																																																																																																																																																																																																																																																																																			
J2	4	6	8																																																																																																																																																																																																																																																																																																																																																																																																																																																																			
J3	6	8	10																																																																																																																																																																																																																																																																																																																																																																																																																																																																			
J4	8	10	12																																																																																																																																																																																																																																																																																																																																																																																																																																																																			
Score 3	8																																																																																																																																																																																																																																																																																																																																																																																																																																																																					
	E1	E2																																																																																																																																																																																																																																																																																																																																																																																																																																																																				
J1	2	4																																																																																																																																																																																																																																																																																																																																																																																																																																																																				
J2	4	6																																																																																																																																																																																																																																																																																																																																																																																																																																																																				
J3	6	8																																																																																																																																																																																																																																																																																																																																																																																																																																																																				
J4	8	10																																																																																																																																																																																																																																																																																																																																																																																																																																																																				
Score 4	10																																																																																																																																																																																																																																																																																																																																																																																																																																																																					
	E1	E2																																																																																																																																																																																																																																																																																																																																																																																																																																																																				
I1	2	4																																																																																																																																																																																																																																																																																																																																																																																																																																																																				
I2	4	6																																																																																																																																																																																																																																																																																																																																																																																																																																																																				
I3	6	8																																																																																																																																																																																																																																																																																																																																																																																																																																																																				
I4	8	10																																																																																																																																																																																																																																																																																																																																																																																																																																																																				
Score 5	4																																																																																																																																																																																																																																																																																																																																																																																																																																																																					
	G1	G2	G3																																																																																																																																																																																																																																																																																																																																																																																																																																																																			
I1	2	4	6																																																																																																																																																																																																																																																																																																																																																																																																																																																																			
I2	4	6	8																																																																																																																																																																																																																																																																																																																																																																																																																																																																			
I3	6	8	10																																																																																																																																																																																																																																																																																																																																																																																																																																																																			
Score 1	6																																																																																																																																																																																																																																																																																																																																																																																																																																																																					
	K1	K2	K3																																																																																																																																																																																																																																																																																																																																																																																																																																																																			
I1	2	4	6																																																																																																																																																																																																																																																																																																																																																																																																																																																																			
I2	4	6	8																																																																																																																																																																																																																																																																																																																																																																																																																																																																			
I3	6	8	10																																																																																																																																																																																																																																																																																																																																																																																																																																																																			
Score 2	6																																																																																																																																																																																																																																																																																																																																																																																																																																																																					
	L1	L2	L3																																																																																																																																																																																																																																																																																																																																																																																																																																																																			
K1	4	9																																																																																																																																																																																																																																																																																																																																																																																																																																																																				
Total Kestabilan	1																																																																																																																																																																																																																																																																																																																																																																																																																																																																					
	M1	M2	M3																																																																																																																																																																																																																																																																																																																																																																																																																																																																			
P1	4	9																																																																																																																																																																																																																																																																																																																																																																																																																																																																				
Total Proses Bekerja	4																																																																																																																																																																																																																																																																																																																																																																																																																																																																					
	N1	N2	N3																																																																																																																																																																																																																																																																																																																																																																																																																																																																			
G1	4	9																																																																																																																																																																																																																																																																																																																																																																																																																																																																				
Total Getaran	1																																																																																																																																																																																																																																																																																																																																																																																																																																																																					
	O1	O2	O3	O4																																																																																																																																																																																																																																																																																																																																																																																																																																																																		
S1	4	9	16																																																																																																																																																																																																																																																																																																																																																																																																																																																																			
Total stress kerja	9																																																																																																																																																																																																																																																																																																																																																																																																																																																																					

Gambar 4 Rekapitulasi Kuisisioner

Rekapitulasi kuisisioner pengamat dan rekapitulasi kuisisioner operator. Ditemukan bahwa pada bagian tubuh punggung mendapatkan skor 28, pada bagian tubuh bahu/lengan mendapatkan skor 28, pada bagian tubuh pergelangan tangan 32, pada bagian tubuh leher mendapatkan skor 12, pada dasar kestabilan beban kerja didapatkan skor 1, pada beban proses kerja mendapatkan nilai skor 4, pada beban proses getaran mendapatka nilai 1, dan pada stress beban kerja mendapatkan skor 9. Jika keseluruhan skor dijumlahkan maka mendapatkan skor 115. Setelah itu akan dihitung untuk mencari skor E.

$$E(\%) = \frac{X}{X_{max}} \times 100\% =$$

$$E(\%) = \frac{115}{176} \times 100\% = 65,34\%$$

Tabel 6 Kategori Skor QEC

QEC score (E)	Action
≤ 40%	Bisa Diterima
41-50%	Penyelidikan lebih lanjut
51-70%	Penyelidikan lebih lanjut dan dilakukan perbaikan segera
> 70%	Penyelidikan lebih lanjut dan dilakukan perbaikan sekarang juga

Pada tabel kategori diatas ditemukan bahwa pada proses potong manual mendapatkan nilai 65,34%, nilai tersebut termasuk dalam kategori resiko tinggi dan perlu dilakukan perbaikan segera.

c. Operator Alat Potong Otomatis

Usulan Perbaikan Fasilitas Kerja pada Produksi Parutan Kelapa Berdasarkan...

EXPOSURE SCORE	NAMA PEKERJA: Mubajir	TANGGAL: -	PEKERJAAN : Potong Otomatis																																																																																												
Punggung	Bahu/Lengan	Pergelangan tangan	Leher																																																																																												
Posisi Punggung A & Beban H	Tringgi C & Ecban H	Gerakan Ecrulang F & Kekuatan J	Posisi Leher C & Durasi I																																																																																												
<table border="1"> <thead> <tr><th></th><th>A1</th><th>A2</th><th>A3</th></tr> </thead> <tbody> <tr><td>H1</td><td>2</td><td>4</td><td>6</td></tr> <tr><td>H2</td><td>4</td><td>6</td><td>8</td></tr> <tr><td>H3</td><td>6</td><td>8</td><td>10</td></tr> <tr><td>H4</td><td>8</td><td>10</td><td>12</td></tr> <tr><td>Score 1</td><td colspan="3">2</td></tr> </tbody> </table>		A1	A2	A3	H1	2	4	6	H2	4	6	8	H3	6	8	10	H4	8	10	12	Score 1	2			<table border="1"> <thead> <tr><th></th><th>C1</th><th>C2</th><th>C3</th></tr> </thead> <tbody> <tr><td>H1</td><td>2</td><td>4</td><td>6</td></tr> <tr><td>H2</td><td>4</td><td>6</td><td>8</td></tr> <tr><td>H3</td><td>6</td><td>8</td><td>10</td></tr> <tr><td>H4</td><td>8</td><td>10</td><td>12</td></tr> <tr><td>Score 1</td><td colspan="3">2</td></tr> </tbody> </table>		C1	C2	C3	H1	2	4	6	H2	4	6	8	H3	6	8	10	H4	8	10	12	Score 1	2			<table border="1"> <thead> <tr><th></th><th>F1</th><th>F2</th><th>F3</th></tr> </thead> <tbody> <tr><td>J1</td><td>2</td><td>4</td><td>6</td></tr> <tr><td>J2</td><td>4</td><td>6</td><td>8</td></tr> <tr><td>J3</td><td>6</td><td>8</td><td>10</td></tr> <tr><td>J4</td><td>8</td><td>10</td><td>12</td></tr> <tr><td>Score 1</td><td colspan="3">6</td></tr> </tbody> </table>		F1	F2	F3	J1	2	4	6	J2	4	6	8	J3	6	8	10	J4	8	10	12	Score 1	6			<table border="1"> <thead> <tr><th></th><th>G1</th><th>G2</th><th>G3</th></tr> </thead> <tbody> <tr><td>I1</td><td>2</td><td>4</td><td>6</td></tr> <tr><td>I2</td><td>4</td><td>6</td><td>8</td></tr> <tr><td>I3</td><td>6</td><td>8</td><td>10</td></tr> <tr><td>Score 1</td><td colspan="3">2</td></tr> </tbody> </table>		G1	G2	G3	I1	2	4	6	I2	4	6	8	I3	6	8	10	Score 1	2		
	A1	A2	A3																																																																																												
H1	2	4	6																																																																																												
H2	4	6	8																																																																																												
H3	6	8	10																																																																																												
H4	8	10	12																																																																																												
Score 1	2																																																																																														
	C1	C2	C3																																																																																												
H1	2	4	6																																																																																												
H2	4	6	8																																																																																												
H3	6	8	10																																																																																												
H4	8	10	12																																																																																												
Score 1	2																																																																																														
	F1	F2	F3																																																																																												
J1	2	4	6																																																																																												
J2	4	6	8																																																																																												
J3	6	8	10																																																																																												
J4	8	10	12																																																																																												
Score 1	6																																																																																														
	G1	G2	G3																																																																																												
I1	2	4	6																																																																																												
I2	4	6	8																																																																																												
I3	6	8	10																																																																																												
Score 1	2																																																																																														
Posisi Punggung A & Durasi I	Tringgi C & Durasi I	Gerakan Ecrulang F & Durasi I	Kebutuhan Visual K & Durasi I																																																																																												
<table border="1"> <thead> <tr><th></th><th>A1</th><th>A2</th><th>A3</th></tr> </thead> <tbody> <tr><td>I1</td><td>2</td><td>4</td><td>6</td></tr> <tr><td>I2</td><td>4</td><td>6</td><td>8</td></tr> <tr><td>I3</td><td>6</td><td>8</td><td>10</td></tr> <tr><td>Score 2</td><td colspan="3">2</td></tr> </tbody> </table>		A1	A2	A3	I1	2	4	6	I2	4	6	8	I3	6	8	10	Score 2	2			<table border="1"> <thead> <tr><th></th><th>C1</th><th>C2</th><th>C3</th></tr> </thead> <tbody> <tr><td>I1</td><td>2</td><td>4</td><td>6</td></tr> <tr><td>I2</td><td>4</td><td>6</td><td>8</td></tr> <tr><td>I3</td><td>6</td><td>8</td><td>10</td></tr> <tr><td>Score 2</td><td colspan="3">2</td></tr> </tbody> </table>		C1	C2	C3	I1	2	4	6	I2	4	6	8	I3	6	8	10	Score 2	2			<table border="1"> <thead> <tr><th></th><th>F1</th><th>F2</th><th>F3</th></tr> </thead> <tbody> <tr><td>I1</td><td>2</td><td>4</td><td>6</td></tr> <tr><td>I2</td><td>4</td><td>6</td><td>8</td></tr> <tr><td>I3</td><td>6</td><td>8</td><td>10</td></tr> <tr><td>Score 2</td><td colspan="3">4</td></tr> </tbody> </table>		F1	F2	F3	I1	2	4	6	I2	4	6	8	I3	6	8	10	Score 2	4			<table border="1"> <thead> <tr><th></th><th>K1</th><th>K2</th><th>K3</th></tr> </thead> <tbody> <tr><td>I1</td><td>2</td><td>4</td><td>6</td></tr> <tr><td>I2</td><td>4</td><td>6</td><td>8</td></tr> <tr><td>I3</td><td>6</td><td>8</td><td>10</td></tr> <tr><td>Score 2</td><td colspan="3">4</td></tr> </tbody> </table>		K1	K2	K3	I1	2	4	6	I2	4	6	8	I3	6	8	10	Score 2	4														
	A1	A2	A3																																																																																												
I1	2	4	6																																																																																												
I2	4	6	8																																																																																												
I3	6	8	10																																																																																												
Score 2	2																																																																																														
	C1	C2	C3																																																																																												
I1	2	4	6																																																																																												
I2	4	6	8																																																																																												
I3	6	8	10																																																																																												
Score 2	2																																																																																														
	F1	F2	F3																																																																																												
I1	2	4	6																																																																																												
I2	4	6	8																																																																																												
I3	6	8	10																																																																																												
Score 2	4																																																																																														
	K1	K2	K3																																																																																												
I1	2	4	6																																																																																												
I2	4	6	8																																																																																												
I3	6	8	10																																																																																												
Score 2	4																																																																																														
Posisi Durasi I & Ecban H	Durasi I & Ecban H	Durasi I & Kekuatan J	Dasar Kestabilan																																																																																												
<table border="1"> <thead> <tr><th></th><th>I1</th><th>I2</th><th>I3</th></tr> </thead> <tbody> <tr><td>H1</td><td>2</td><td>4</td><td>6</td></tr> <tr><td>H2</td><td>4</td><td>6</td><td>8</td></tr> <tr><td>H3</td><td>6</td><td>8</td><td>10</td></tr> <tr><td>H4</td><td>8</td><td>10</td><td>12</td></tr> <tr><td>Score 3</td><td colspan="3">2</td></tr> </tbody> </table>		I1	I2	I3	H1	2	4	6	H2	4	6	8	H3	6	8	10	H4	8	10	12	Score 3	2			<table border="1"> <thead> <tr><th></th><th>I1</th><th>I2</th><th>I3</th></tr> </thead> <tbody> <tr><td>H1</td><td>2</td><td>4</td><td>6</td></tr> <tr><td>H2</td><td>4</td><td>6</td><td>8</td></tr> <tr><td>H3</td><td>6</td><td>8</td><td>10</td></tr> <tr><td>H4</td><td>8</td><td>10</td><td>12</td></tr> <tr><td>Score 3</td><td colspan="3">2</td></tr> </tbody> </table>		I1	I2	I3	H1	2	4	6	H2	4	6	8	H3	6	8	10	H4	8	10	12	Score 3	2			<table border="1"> <thead> <tr><th></th><th>I1</th><th>I2</th><th>I3</th></tr> </thead> <tbody> <tr><td>J1</td><td>2</td><td>4</td><td>6</td></tr> <tr><td>J2</td><td>4</td><td>6</td><td>8</td></tr> <tr><td>J3</td><td>6</td><td>8</td><td>10</td></tr> <tr><td>J4</td><td>8</td><td>10</td><td>12</td></tr> <tr><td>Score 3</td><td colspan="3">4</td></tr> </tbody> </table>		I1	I2	I3	J1	2	4	6	J2	4	6	8	J3	6	8	10	J4	8	10	12	Score 3	4			<table border="1"> <thead> <tr><th></th><th>L1</th><th>L2</th><th>L3</th></tr> </thead> <tbody> <tr><td>I</td><td>4</td><td>9</td><td></td></tr> <tr><td>Total Kestabilan</td><td colspan="3">1</td></tr> </tbody> </table>		L1	L2	L3	I	4	9		Total Kestabilan	1										
	I1	I2	I3																																																																																												
H1	2	4	6																																																																																												
H2	4	6	8																																																																																												
H3	6	8	10																																																																																												
H4	8	10	12																																																																																												
Score 3	2																																																																																														
	I1	I2	I3																																																																																												
H1	2	4	6																																																																																												
H2	4	6	8																																																																																												
H3	6	8	10																																																																																												
H4	8	10	12																																																																																												
Score 3	2																																																																																														
	I1	I2	I3																																																																																												
J1	2	4	6																																																																																												
J2	4	6	8																																																																																												
J3	6	8	10																																																																																												
J4	8	10	12																																																																																												
Score 3	4																																																																																														
	L1	L2	L3																																																																																												
I	4	9																																																																																													
Total Kestabilan	1																																																																																														
Untuk pekerjaan statis gunakan skoring 4 Untuk material handling gunakan skoring 5 dan 6	Frekkuensi D & Ecban H	Posisi pergelangan tangan E & Kekuatan J	Proses Bekerja																																																																																												
	<table border="1"> <thead> <tr><th></th><th>D1</th><th>D2</th><th>D3</th></tr> </thead> <tbody> <tr><td>H1</td><td>2</td><td>4</td><td>6</td></tr> <tr><td>H2</td><td>4</td><td>6</td><td>8</td></tr> <tr><td>H3</td><td>6</td><td>8</td><td>10</td></tr> <tr><td>H4</td><td>8</td><td>10</td><td>12</td></tr> <tr><td>Score 4</td><td colspan="3">6</td></tr> </tbody> </table>		D1	D2	D3	H1	2	4	6	H2	4	6	8	H3	6	8	10	H4	8	10	12	Score 4	6			<table border="1"> <thead> <tr><th></th><th>E1</th><th>E2</th></tr> </thead> <tbody> <tr><td>J1</td><td>2</td><td>4</td></tr> <tr><td>J2</td><td>4</td><td>6</td></tr> <tr><td>J3</td><td>6</td><td>8</td></tr> <tr><td>J4</td><td>8</td><td>10</td></tr> <tr><td>Score 4</td><td colspan="2">4</td></tr> </tbody> </table>		E1	E2	J1	2	4	J2	4	6	J3	6	8	J4	8	10	Score 4	4		<table border="1"> <thead> <tr><th></th><th>M1</th><th>M2</th><th>M3</th></tr> </thead> <tbody> <tr><td>I</td><td>4</td><td>9</td><td></td></tr> <tr><td>Total Proses Bekerja</td><td colspan="3">4</td></tr> </tbody> </table>		M1	M2	M3	I	4	9		Total Proses Bekerja	4																																								
	D1	D2	D3																																																																																												
H1	2	4	6																																																																																												
H2	4	6	8																																																																																												
H3	6	8	10																																																																																												
H4	8	10	12																																																																																												
Score 4	6																																																																																														
	E1	E2																																																																																													
J1	2	4																																																																																													
J2	4	6																																																																																													
J3	6	8																																																																																													
J4	8	10																																																																																													
Score 4	4																																																																																														
	M1	M2	M3																																																																																												
I	4	9																																																																																													
Total Proses Bekerja	4																																																																																														
	Frekkuensi E & durasi I	Posisi pergelangan tangan E & durasi I	Getaran																																																																																												
	<table border="1"> <thead> <tr><th></th><th>D1</th><th>D2</th><th>D3</th></tr> </thead> <tbody> <tr><td>I1</td><td>2</td><td>4</td><td>6</td></tr> <tr><td>I2</td><td>4</td><td>6</td><td>8</td></tr> <tr><td>I3</td><td>6</td><td>8</td><td>10</td></tr> <tr><td>Score 5</td><td colspan="3">6</td></tr> </tbody> </table>		D1	D2	D3	I1	2	4	6	I2	4	6	8	I3	6	8	10	Score 5	6			<table border="1"> <thead> <tr><th></th><th>E1</th><th>E2</th></tr> </thead> <tbody> <tr><td>I1</td><td>2</td><td>4</td></tr> <tr><td>I2</td><td>4</td><td>6</td></tr> <tr><td>I3</td><td>6</td><td>8</td></tr> <tr><td>Score 5</td><td colspan="2">2</td></tr> </tbody> </table>		E1	E2	I1	2	4	I2	4	6	I3	6	8	Score 5	2		<table border="1"> <thead> <tr><th></th><th>N1</th><th>N2</th><th>N3</th></tr> </thead> <tbody> <tr><td>I</td><td>4</td><td>9</td><td></td></tr> <tr><td>Total Getaran</td><td colspan="3">4</td></tr> </tbody> </table>		N1	N2	N3	I	4	9		Total Getaran	4																																															
	D1	D2	D3																																																																																												
I1	2	4	6																																																																																												
I2	4	6	8																																																																																												
I3	6	8	10																																																																																												
Score 5	6																																																																																														
	E1	E2																																																																																													
I1	2	4																																																																																													
I2	4	6																																																																																													
I3	6	8																																																																																													
Score 5	2																																																																																														
	N1	N2	N3																																																																																												
I	4	9																																																																																													
Total Getaran	4																																																																																														
	Frekkuensi E & durasi I	Total skor pergelangan tangan = total skor 1 sampai 5	Stress Kerja																																																																																												
	<table border="1"> <thead> <tr><th></th><th>B3</th><th>B4</th><th>B5</th></tr> </thead> <tbody> <tr><td>I1</td><td>2</td><td>4</td><td>6</td></tr> <tr><td>I2</td><td>4</td><td>6</td><td>8</td></tr> <tr><td>I3</td><td>6</td><td>8</td><td>10</td></tr> <tr><td>Score 6</td><td colspan="3">6</td></tr> </tbody> </table>		B3	B4	B5	I1	2	4	6	I2	4	6	8	I3	6	8	10	Score 6	6			18	<table border="1"> <thead> <tr><th></th><th>O1</th><th>O2</th><th>O3</th><th>O4</th></tr> </thead> <tbody> <tr><td>I</td><td>4</td><td>9</td><td>16</td><td></td></tr> <tr><td>Total stress kerja</td><td colspan="4">1</td></tr> </tbody> </table>		O1	O2	O3	O4	I	4	9	16		Total stress kerja	1																																																												
	B3	B4	B5																																																																																												
I1	2	4	6																																																																																												
I2	4	6	8																																																																																												
I3	6	8	10																																																																																												
Score 6	6																																																																																														
	O1	O2	O3	O4																																																																																											
I	4	9	16																																																																																												
Total stress kerja	1																																																																																														
	Total skor punggung = total skor 1 sampai 4 atau total skor 1 sampai 3 ditambah 5&6																																																																																														
10																																																																																															

Gambar 5 Rekapitulasi Kuisisioner

Rekapitulasi kuisisioner pengamat dan rekapitulasi kuisisioner operator. Ditemukan bahwa pada bagian tubuh punggung mendapatkan skor 10, pada bagian tubuh bahu/lengan mendapatkan skor 18, pada bagian tubuh pergelangan tangan 20, pada bagian tubuh leher mendapatkan skor 6, pada dasar kestabilan beban kerja didapatkan skor 1, pada beban proses kerja mendapatkan nilai skor 4, pada beban proses getaran mendapatka nilai 4, dan pada stress beban kerja mendapatkan skor 1. Jika keseluruhan skor dijumlahkan maka mendapatkan skor 64. Setelah itu akan dihitung untuk mencari skor E.

$$E(\%) = \frac{X}{X_{max}} \times 100\% =$$

$$E(\%) = \frac{64}{176} \times 100\% = 39,5\%$$

Tabel 7 Kategori Skor QEC

QEC score (E)	Aksi
≤ 40%	Bisa Diterima
41-50%	Penyelidikan lebih lanjut
51-70%	Penyelidikan lebih lanjut dan dilakukan perbaikan segera
> 70%	Penyelidikan lebih lanjut dan dilakukan perbaikan sekarang juga

Pada tabel kategori diatas ditemukan bahwa pada proses potong otomatis mendapatkan nilai 39,5%, nilai tersebut termasuk dalam kategori resiko rendah dan tidak perlu dilakukan perbaikan.

d. Operator Mesin Bubut

EXPOSURE SCORE	NAMA PEKERJA: Samsul	TANGGAL :	PEKERJAAN : Mesin Bubut																																																																																																																																																																																																																																																																																																																																																																																																																	
Punggung Posisi Punggung A & Beban H <table border="1"> <tr><th>A1</th><th>A2</th><th>A3</th></tr> <tr><td>H1</td><td>2</td><td>4</td><td>6</td></tr> <tr><td>H2</td><td>4</td><td>6</td><td>8</td></tr> <tr><td>H3</td><td>6</td><td>8</td><td>10</td></tr> <tr><td>H4</td><td>8</td><td>10</td><td>12</td></tr> <tr><td>Score 1</td><td colspan="3">2</td></tr> </table> Posisi Punggung A & Durasi I <table border="1"> <tr><th>A1</th><th>A2</th><th>A3</th></tr> <tr><td>I1</td><td>2</td><td>4</td><td>6</td></tr> <tr><td>I2</td><td>4</td><td>6</td><td>8</td></tr> <tr><td>I3</td><td>6</td><td>8</td><td>10</td></tr> <tr><td>Score 2</td><td colspan="3">2</td></tr> </table> Posisi Durasi I & Beban H <table border="1"> <tr><th>I1</th><th>I2</th><th>I3</th></tr> <tr><td>H1</td><td>2</td><td>4</td><td>6</td></tr> <tr><td>H2</td><td>4</td><td>6</td><td>8</td></tr> <tr><td>H3</td><td>6</td><td>8</td><td>10</td></tr> <tr><td>H4</td><td>8</td><td>10</td><td>12</td></tr> <tr><td>Score 3</td><td colspan="3">2</td></tr> </table> Untuk pekerjaan statis gunakan skoring 4 Untuk material handling gunakan skoring 5 dan 6 Posisi Statis B & Durasi I <table border="1"> <tr><th>B1</th><th>B2</th></tr> <tr><td>I1</td><td>2</td><td>4</td></tr> <tr><td>I2</td><td>4</td><td>6</td></tr> <tr><td>I3</td><td>6</td><td>8</td></tr> <tr><td>Score 4</td><td colspan="2">4</td></tr> </table> Frekuensi B & Beban H <table border="1"> <tr><th>B3</th><th>B4</th><th>B5</th></tr> <tr><td>H1</td><td>2</td><td>4</td><td>6</td></tr> <tr><td>H2</td><td>4</td><td>6</td><td>8</td></tr> <tr><td>H3</td><td>6</td><td>8</td><td>10</td></tr> <tr><td>H4</td><td>8</td><td>10</td><td>12</td></tr> <tr><td>Score 5</td><td colspan="3">2</td></tr> </table> Frekuensi B & durasi I <table border="1"> <tr><th>B3</th><th>B4</th><th>B5</th></tr> <tr><td>I1</td><td>2</td><td>4</td><td>6</td></tr> <tr><td>I2</td><td>4</td><td>6</td><td>8</td></tr> <tr><td>I3</td><td>6</td><td>8</td><td>10</td></tr> <tr><td>Score 6</td><td colspan="3">2</td></tr> </table> Total skor punggung = total skor 1 sampai 4 atau total skor 1 sampai 3 ditambah 5&6 10	A1	A2	A3	H1	2	4	6	H2	4	6	8	H3	6	8	10	H4	8	10	12	Score 1	2			A1	A2	A3	I1	2	4	6	I2	4	6	8	I3	6	8	10	Score 2	2			I1	I2	I3	H1	2	4	6	H2	4	6	8	H3	6	8	10	H4	8	10	12	Score 3	2			B1	B2	I1	2	4	I2	4	6	I3	6	8	Score 4	4		B3	B4	B5	H1	2	4	6	H2	4	6	8	H3	6	8	10	H4	8	10	12	Score 5	2			B3	B4	B5	I1	2	4	6	I2	4	6	8	I3	6	8	10	Score 6	2			Bahu/Lengan Tinggi C & Beban H <table border="1"> <tr><th>C1</th><th>C2</th><th>C3</th></tr> <tr><td>H1</td><td>2</td><td>4</td><td>6</td></tr> <tr><td>H2</td><td>4</td><td>6</td><td>8</td></tr> <tr><td>H3</td><td>6</td><td>8</td><td>10</td></tr> <tr><td>H4</td><td>8</td><td>10</td><td>12</td></tr> <tr><td>Score 1</td><td colspan="3">2</td></tr> </table> Tinggi C & Durasi I <table border="1"> <tr><th>C1</th><th>C2</th><th>C3</th></tr> <tr><td>I1</td><td>2</td><td>4</td><td>6</td></tr> <tr><td>I2</td><td>4</td><td>6</td><td>8</td></tr> <tr><td>I3</td><td>6</td><td>8</td><td>10</td></tr> <tr><td>Score 2</td><td colspan="3">2</td></tr> </table> Durasi I & Beban H <table border="1"> <tr><th>I1</th><th>I2</th><th>I3</th></tr> <tr><td>H1</td><td>2</td><td>4</td><td>6</td></tr> <tr><td>H2</td><td>4</td><td>6</td><td>8</td></tr> <tr><td>H3</td><td>6</td><td>8</td><td>10</td></tr> <tr><td>H4</td><td>8</td><td>10</td><td>12</td></tr> <tr><td>Score 3</td><td colspan="3">2</td></tr> </table> Frekuensi D & Beban H <table border="1"> <tr><th>D1</th><th>D2</th><th>D3</th></tr> <tr><td>H1</td><td>2</td><td>4</td><td>6</td></tr> <tr><td>H2</td><td>4</td><td>6</td><td>8</td></tr> <tr><td>H3</td><td>6</td><td>8</td><td>10</td></tr> <tr><td>H4</td><td>8</td><td>10</td><td>12</td></tr> <tr><td>Score 4</td><td colspan="3">2</td></tr> </table> Frekuensi D & durasi I <table border="1"> <tr><th>D1</th><th>D2</th><th>D3</th></tr> <tr><td>I1</td><td>2</td><td>4</td><td>6</td></tr> <tr><td>I2</td><td>4</td><td>6</td><td>8</td></tr> <tr><td>I3</td><td>6</td><td>8</td><td>10</td></tr> <tr><td>Score 5</td><td colspan="3">2</td></tr> </table> Total skor bahu/lengan = total skor 1 sampai 5 10	C1	C2	C3	H1	2	4	6	H2	4	6	8	H3	6	8	10	H4	8	10	12	Score 1	2			C1	C2	C3	I1	2	4	6	I2	4	6	8	I3	6	8	10	Score 2	2			I1	I2	I3	H1	2	4	6	H2	4	6	8	H3	6	8	10	H4	8	10	12	Score 3	2			D1	D2	D3	H1	2	4	6	H2	4	6	8	H3	6	8	10	H4	8	10	12	Score 4	2			D1	D2	D3	I1	2	4	6	I2	4	6	8	I3	6	8	10	Score 5	2			Pergelangan tangan Gerakan Berulang F & Kekuatan J <table border="1"> <tr><th>F1</th><th>F2</th><th>F3</th></tr> <tr><td>J1</td><td>2</td><td>4</td><td>6</td></tr> <tr><td>J2</td><td>4</td><td>6</td><td>8</td></tr> <tr><td>J3</td><td>6</td><td>8</td><td>10</td></tr> <tr><td>J4</td><td>8</td><td>10</td><td>12</td></tr> <tr><td>Score 1</td><td colspan="3">4</td></tr> </table> Gerakan Berulang F & Durasi I <table border="1"> <tr><th>F1</th><th>F2</th><th>F3</th></tr> <tr><td>I1</td><td>2</td><td>4</td><td>6</td></tr> <tr><td>I2</td><td>4</td><td>6</td><td>8</td></tr> <tr><td>I3</td><td>6</td><td>8</td><td>10</td></tr> <tr><td>Score 2</td><td colspan="3">2</td></tr> </table> Durasi I & Kekuatan J <table border="1"> <tr><th>I1</th><th>I2</th><th>I3</th></tr> <tr><td>J1</td><td>2</td><td>4</td><td>6</td></tr> <tr><td>J2</td><td>4</td><td>6</td><td>8</td></tr> <tr><td>J3</td><td>6</td><td>8</td><td>10</td></tr> <tr><td>J4</td><td>8</td><td>10</td><td>12</td></tr> <tr><td>Score 3</td><td colspan="3">4</td></tr> </table> Posisi pergelangan tangan E & Kekuatan J <table border="1"> <tr><th>E1</th><th>E2</th></tr> <tr><td>J1</td><td>2</td><td>4</td></tr> <tr><td>J2</td><td>4</td><td>6</td></tr> <tr><td>J3</td><td>6</td><td>8</td></tr> <tr><td>J4</td><td>8</td><td>10</td></tr> <tr><td>Score 4</td><td colspan="2">4</td></tr> </table> Posisi pergelangan tangan E & durasi I <table border="1"> <tr><th>E1</th><th>E2</th></tr> <tr><td>I1</td><td>2</td><td>4</td></tr> <tr><td>I2</td><td>4</td><td>6</td></tr> <tr><td>I3</td><td>6</td><td>8</td></tr> <tr><td>Score 5</td><td colspan="2">2</td></tr> </table> Total skor pergelangan tangan = total skor 1 sampai 5 16	F1	F2	F3	J1	2	4	6	J2	4	6	8	J3	6	8	10	J4	8	10	12	Score 1	4			F1	F2	F3	I1	2	4	6	I2	4	6	8	I3	6	8	10	Score 2	2			I1	I2	I3	J1	2	4	6	J2	4	6	8	J3	6	8	10	J4	8	10	12	Score 3	4			E1	E2	J1	2	4	J2	4	6	J3	6	8	J4	8	10	Score 4	4		E1	E2	I1	2	4	I2	4	6	I3	6	8	Score 5	2		Leher Posisi Leher G & Durasi I <table border="1"> <tr><th>G1</th><th>G2</th><th>G3</th></tr> <tr><td>I1</td><td>2</td><td>4</td><td>6</td></tr> <tr><td>I2</td><td>4</td><td>6</td><td>8</td></tr> <tr><td>I3</td><td>6</td><td>8</td><td>10</td></tr> <tr><td>Score 1</td><td colspan="3">2</td></tr> </table> Kebutuhan Visual K & Durasi I <table border="1"> <tr><th>K1</th><th>K2</th><th>K3</th></tr> <tr><td>I1</td><td>2</td><td>4</td><td>6</td></tr> <tr><td>I2</td><td>4</td><td>6</td><td>8</td></tr> <tr><td>I3</td><td>6</td><td>8</td><td>10</td></tr> <tr><td>Score 2</td><td colspan="3">4</td></tr> </table> Total skor pergelangan tangan = total skor 1 sampai 2 6 Dasar Kestabilan <table border="1"> <tr><th>L1</th><th>L2</th><th>L3</th></tr> <tr><td>K1</td><td>4</td><td>9</td></tr> <tr><td>Total Kestabilan</td><td colspan="2">1</td></tr> </table> Proses Bekerja <table border="1"> <tr><th>M1</th><th>M2</th><th>M3</th></tr> <tr><td>I1</td><td>4</td><td>9</td></tr> <tr><td>Total Proses Bekerja</td><td colspan="2">4</td></tr> </table> Getaran <table border="1"> <tr><th>N1</th><th>N2</th><th>N3</th></tr> <tr><td>I1</td><td>4</td><td>9</td></tr> <tr><td>Total Getaran</td><td colspan="2">1</td></tr> </table> Stress Kerja <table border="1"> <tr><th>O1</th><th>O2</th><th>O3</th><th>O4</th></tr> <tr><td>I1</td><td>4</td><td>9</td><td>16</td></tr> <tr><td>Total stress kerja</td><td colspan="3">1</td></tr> </table>	G1	G2	G3	I1	2	4	6	I2	4	6	8	I3	6	8	10	Score 1	2			K1	K2	K3	I1	2	4	6	I2	4	6	8	I3	6	8	10	Score 2	4			L1	L2	L3	K1	4	9	Total Kestabilan	1		M1	M2	M3	I1	4	9	Total Proses Bekerja	4		N1	N2	N3	I1	4	9	Total Getaran	1		O1	O2	O3	O4	I1	4	9	16	Total stress kerja	1		
A1	A2	A3																																																																																																																																																																																																																																																																																																																																																																																																																		
H1	2	4	6																																																																																																																																																																																																																																																																																																																																																																																																																	
H2	4	6	8																																																																																																																																																																																																																																																																																																																																																																																																																	
H3	6	8	10																																																																																																																																																																																																																																																																																																																																																																																																																	
H4	8	10	12																																																																																																																																																																																																																																																																																																																																																																																																																	
Score 1	2																																																																																																																																																																																																																																																																																																																																																																																																																			
A1	A2	A3																																																																																																																																																																																																																																																																																																																																																																																																																		
I1	2	4	6																																																																																																																																																																																																																																																																																																																																																																																																																	
I2	4	6	8																																																																																																																																																																																																																																																																																																																																																																																																																	
I3	6	8	10																																																																																																																																																																																																																																																																																																																																																																																																																	
Score 2	2																																																																																																																																																																																																																																																																																																																																																																																																																			
I1	I2	I3																																																																																																																																																																																																																																																																																																																																																																																																																		
H1	2	4	6																																																																																																																																																																																																																																																																																																																																																																																																																	
H2	4	6	8																																																																																																																																																																																																																																																																																																																																																																																																																	
H3	6	8	10																																																																																																																																																																																																																																																																																																																																																																																																																	
H4	8	10	12																																																																																																																																																																																																																																																																																																																																																																																																																	
Score 3	2																																																																																																																																																																																																																																																																																																																																																																																																																			
B1	B2																																																																																																																																																																																																																																																																																																																																																																																																																			
I1	2	4																																																																																																																																																																																																																																																																																																																																																																																																																		
I2	4	6																																																																																																																																																																																																																																																																																																																																																																																																																		
I3	6	8																																																																																																																																																																																																																																																																																																																																																																																																																		
Score 4	4																																																																																																																																																																																																																																																																																																																																																																																																																			
B3	B4	B5																																																																																																																																																																																																																																																																																																																																																																																																																		
H1	2	4	6																																																																																																																																																																																																																																																																																																																																																																																																																	
H2	4	6	8																																																																																																																																																																																																																																																																																																																																																																																																																	
H3	6	8	10																																																																																																																																																																																																																																																																																																																																																																																																																	
H4	8	10	12																																																																																																																																																																																																																																																																																																																																																																																																																	
Score 5	2																																																																																																																																																																																																																																																																																																																																																																																																																			
B3	B4	B5																																																																																																																																																																																																																																																																																																																																																																																																																		
I1	2	4	6																																																																																																																																																																																																																																																																																																																																																																																																																	
I2	4	6	8																																																																																																																																																																																																																																																																																																																																																																																																																	
I3	6	8	10																																																																																																																																																																																																																																																																																																																																																																																																																	
Score 6	2																																																																																																																																																																																																																																																																																																																																																																																																																			
C1	C2	C3																																																																																																																																																																																																																																																																																																																																																																																																																		
H1	2	4	6																																																																																																																																																																																																																																																																																																																																																																																																																	
H2	4	6	8																																																																																																																																																																																																																																																																																																																																																																																																																	
H3	6	8	10																																																																																																																																																																																																																																																																																																																																																																																																																	
H4	8	10	12																																																																																																																																																																																																																																																																																																																																																																																																																	
Score 1	2																																																																																																																																																																																																																																																																																																																																																																																																																			
C1	C2	C3																																																																																																																																																																																																																																																																																																																																																																																																																		
I1	2	4	6																																																																																																																																																																																																																																																																																																																																																																																																																	
I2	4	6	8																																																																																																																																																																																																																																																																																																																																																																																																																	
I3	6	8	10																																																																																																																																																																																																																																																																																																																																																																																																																	
Score 2	2																																																																																																																																																																																																																																																																																																																																																																																																																			
I1	I2	I3																																																																																																																																																																																																																																																																																																																																																																																																																		
H1	2	4	6																																																																																																																																																																																																																																																																																																																																																																																																																	
H2	4	6	8																																																																																																																																																																																																																																																																																																																																																																																																																	
H3	6	8	10																																																																																																																																																																																																																																																																																																																																																																																																																	
H4	8	10	12																																																																																																																																																																																																																																																																																																																																																																																																																	
Score 3	2																																																																																																																																																																																																																																																																																																																																																																																																																			
D1	D2	D3																																																																																																																																																																																																																																																																																																																																																																																																																		
H1	2	4	6																																																																																																																																																																																																																																																																																																																																																																																																																	
H2	4	6	8																																																																																																																																																																																																																																																																																																																																																																																																																	
H3	6	8	10																																																																																																																																																																																																																																																																																																																																																																																																																	
H4	8	10	12																																																																																																																																																																																																																																																																																																																																																																																																																	
Score 4	2																																																																																																																																																																																																																																																																																																																																																																																																																			
D1	D2	D3																																																																																																																																																																																																																																																																																																																																																																																																																		
I1	2	4	6																																																																																																																																																																																																																																																																																																																																																																																																																	
I2	4	6	8																																																																																																																																																																																																																																																																																																																																																																																																																	
I3	6	8	10																																																																																																																																																																																																																																																																																																																																																																																																																	
Score 5	2																																																																																																																																																																																																																																																																																																																																																																																																																			
F1	F2	F3																																																																																																																																																																																																																																																																																																																																																																																																																		
J1	2	4	6																																																																																																																																																																																																																																																																																																																																																																																																																	
J2	4	6	8																																																																																																																																																																																																																																																																																																																																																																																																																	
J3	6	8	10																																																																																																																																																																																																																																																																																																																																																																																																																	
J4	8	10	12																																																																																																																																																																																																																																																																																																																																																																																																																	
Score 1	4																																																																																																																																																																																																																																																																																																																																																																																																																			
F1	F2	F3																																																																																																																																																																																																																																																																																																																																																																																																																		
I1	2	4	6																																																																																																																																																																																																																																																																																																																																																																																																																	
I2	4	6	8																																																																																																																																																																																																																																																																																																																																																																																																																	
I3	6	8	10																																																																																																																																																																																																																																																																																																																																																																																																																	
Score 2	2																																																																																																																																																																																																																																																																																																																																																																																																																			
I1	I2	I3																																																																																																																																																																																																																																																																																																																																																																																																																		
J1	2	4	6																																																																																																																																																																																																																																																																																																																																																																																																																	
J2	4	6	8																																																																																																																																																																																																																																																																																																																																																																																																																	
J3	6	8	10																																																																																																																																																																																																																																																																																																																																																																																																																	
J4	8	10	12																																																																																																																																																																																																																																																																																																																																																																																																																	
Score 3	4																																																																																																																																																																																																																																																																																																																																																																																																																			
E1	E2																																																																																																																																																																																																																																																																																																																																																																																																																			
J1	2	4																																																																																																																																																																																																																																																																																																																																																																																																																		
J2	4	6																																																																																																																																																																																																																																																																																																																																																																																																																		
J3	6	8																																																																																																																																																																																																																																																																																																																																																																																																																		
J4	8	10																																																																																																																																																																																																																																																																																																																																																																																																																		
Score 4	4																																																																																																																																																																																																																																																																																																																																																																																																																			
E1	E2																																																																																																																																																																																																																																																																																																																																																																																																																			
I1	2	4																																																																																																																																																																																																																																																																																																																																																																																																																		
I2	4	6																																																																																																																																																																																																																																																																																																																																																																																																																		
I3	6	8																																																																																																																																																																																																																																																																																																																																																																																																																		
Score 5	2																																																																																																																																																																																																																																																																																																																																																																																																																			
G1	G2	G3																																																																																																																																																																																																																																																																																																																																																																																																																		
I1	2	4	6																																																																																																																																																																																																																																																																																																																																																																																																																	
I2	4	6	8																																																																																																																																																																																																																																																																																																																																																																																																																	
I3	6	8	10																																																																																																																																																																																																																																																																																																																																																																																																																	
Score 1	2																																																																																																																																																																																																																																																																																																																																																																																																																			
K1	K2	K3																																																																																																																																																																																																																																																																																																																																																																																																																		
I1	2	4	6																																																																																																																																																																																																																																																																																																																																																																																																																	
I2	4	6	8																																																																																																																																																																																																																																																																																																																																																																																																																	
I3	6	8	10																																																																																																																																																																																																																																																																																																																																																																																																																	
Score 2	4																																																																																																																																																																																																																																																																																																																																																																																																																			
L1	L2	L3																																																																																																																																																																																																																																																																																																																																																																																																																		
K1	4	9																																																																																																																																																																																																																																																																																																																																																																																																																		
Total Kestabilan	1																																																																																																																																																																																																																																																																																																																																																																																																																			
M1	M2	M3																																																																																																																																																																																																																																																																																																																																																																																																																		
I1	4	9																																																																																																																																																																																																																																																																																																																																																																																																																		
Total Proses Bekerja	4																																																																																																																																																																																																																																																																																																																																																																																																																			
N1	N2	N3																																																																																																																																																																																																																																																																																																																																																																																																																		
I1	4	9																																																																																																																																																																																																																																																																																																																																																																																																																		
Total Getaran	1																																																																																																																																																																																																																																																																																																																																																																																																																			
O1	O2	O3	O4																																																																																																																																																																																																																																																																																																																																																																																																																	
I1	4	9	16																																																																																																																																																																																																																																																																																																																																																																																																																	
Total stress kerja	1																																																																																																																																																																																																																																																																																																																																																																																																																			

Gambar 6 Rekapitulasi Kuisioner

Rekapitulasi kuisioner pengamat dan rekapitulasi kuisioner operator. Ditemukan bahwa pada bagian tubuh punggung mendapatkan skor 10, pada bagian tubuh bahu/lengan mendapatkan skor 10, pada bagian tubuh pergelangan tangan 16, pada bagian tubuh leher mendapatkan skor 6, pada dasar kestabilan beban kerja didapatkan skor 1, pada beban proses kerja mendapatkan nilai skor 4, pada beban proses getaran mendapatka nilai 1, dan pada stress beban kerja mendapatkan skor 1. Jika keseluruhan skor dijumlahkan maka mendapatkan skor keseluruhan 49. Setelah itu akan dihitung untuk mencari skor E.

$$E(\%) = \frac{X}{X_{max}} \times 100\% =$$

$$E(\%) = \frac{49}{176} \times 100\% = 30,24\%$$

Tabel 8 Kategori Skor QEC

QEC score (E)	Aksi
≤ 40%	Bisa Diterima
41-50%	Penyelidikan lebih lanjut
51-70%	Penyelidikan lebih lanjut dan dilakukan perbaikan segera
> 70%	Penyelidikan lebih lanjut dan dilakukan perbaikan sekarang juga

Pada tabel kategori diatas ditemukan bahwa pada proses potong otomatis mendapatkan nilai 30,24%, nilai tersebut termasuk dalam kategori resiko rendah dan tidak perlu dilakukan perbaikan.

e. Operator Pengelasan

Usulan Perbaikan Fasilitas Kerja pada Produksi Parutan Kelapa Berdasarkan...

EXPOSURE SCORE	NAMA PEKERJA: Supriyanto	TANGGAL :	PEKERJAAN : Pengelasan																																																																																																																																																																																																																																																																																																																																																																																																																	
Punggung Posisi Punggung A & Beban H <table border="1" style="width: 100%; border-collapse: collapse;"> <tr><th>A1</th><th>A2</th><th>A3</th></tr> <tr><td>H1</td><td>2</td><td>4</td><td>6</td></tr> <tr><td>H2</td><td>4</td><td>6</td><td>8</td></tr> <tr><td>H3</td><td>6</td><td>8</td><td>10</td></tr> <tr><td>H4</td><td>8</td><td>10</td><td>12</td></tr> <tr><td>Score 1</td><td colspan="3">3</td></tr> </table> Posisi Punggung A & Durasi I <table border="1" style="width: 100%; border-collapse: collapse;"> <tr><th>A1</th><th>A2</th><th>A3</th></tr> <tr><td>I1</td><td>2</td><td>4</td><td>6</td></tr> <tr><td>I2</td><td>4</td><td>6</td><td>8</td></tr> <tr><td>I3</td><td>6</td><td>8</td><td>10</td></tr> <tr><td>Score 2</td><td colspan="3">3</td></tr> </table> Posisi Durasi I & Beban H <table border="1" style="width: 100%; border-collapse: collapse;"> <tr><th>I1</th><th>I2</th><th>I3</th></tr> <tr><td>H1</td><td>2</td><td>4</td><td>6</td></tr> <tr><td>H2</td><td>4</td><td>6</td><td>8</td></tr> <tr><td>H3</td><td>6</td><td>8</td><td>10</td></tr> <tr><td>H4</td><td>8</td><td>10</td><td>12</td></tr> <tr><td>Score 3</td><td colspan="3">6</td></tr> </table> <p>Untuk pekerjaan statis gunakan skoring 4 Untuk material handling gunakan skoring 5 dan 6</p> Posisi Statis E & Durasi I <table border="1" style="width: 100%; border-collapse: collapse;"> <tr><th>B1</th><th>B2</th></tr> <tr><td>E1</td><td>2</td><td>4</td></tr> <tr><td>E2</td><td>4</td><td>6</td></tr> <tr><td>E3</td><td>6</td><td>8</td></tr> <tr><td>Score 4</td><td colspan="2">3</td></tr> </table> Frekuensi E & Beban H <table border="1" style="width: 100%; border-collapse: collapse;"> <tr><th>B3</th><th>B4</th><th>B5</th></tr> <tr><td>H1</td><td>2</td><td>4</td><td>6</td></tr> <tr><td>H2</td><td>4</td><td>6</td><td>8</td></tr> <tr><td>H3</td><td>6</td><td>8</td><td>10</td></tr> <tr><td>H4</td><td>8</td><td>10</td><td>12</td></tr> <tr><td>Score 5</td><td colspan="3">6</td></tr> </table> Frekuensi E & durasi I <table border="1" style="width: 100%; border-collapse: collapse;"> <tr><th>B3</th><th>B4</th><th>B5</th></tr> <tr><td>I1</td><td>2</td><td>4</td><td>6</td></tr> <tr><td>I2</td><td>4</td><td>6</td><td>8</td></tr> <tr><td>I3</td><td>6</td><td>8</td><td>10</td></tr> <tr><td>Score 6</td><td colspan="3">6</td></tr> </table> <p>Total skor punggung = total skor 1 sampai 4 atau total skor 1 sampai 3 ditambah 5&6 34</p>	A1	A2	A3	H1	2	4	6	H2	4	6	8	H3	6	8	10	H4	8	10	12	Score 1	3			A1	A2	A3	I1	2	4	6	I2	4	6	8	I3	6	8	10	Score 2	3			I1	I2	I3	H1	2	4	6	H2	4	6	8	H3	6	8	10	H4	8	10	12	Score 3	6			B1	B2	E1	2	4	E2	4	6	E3	6	8	Score 4	3		B3	B4	B5	H1	2	4	6	H2	4	6	8	H3	6	8	10	H4	8	10	12	Score 5	6			B3	B4	B5	I1	2	4	6	I2	4	6	8	I3	6	8	10	Score 6	6			Tubuh/Lengan Tinggi C & Beban H <table border="1" style="width: 100%; border-collapse: collapse;"> <tr><th>C1</th><th>C2</th><th>C3</th></tr> <tr><td>H1</td><td>2</td><td>4</td><td>6</td></tr> <tr><td>H2</td><td>4</td><td>6</td><td>8</td></tr> <tr><td>H3</td><td>6</td><td>8</td><td>10</td></tr> <tr><td>H4</td><td>8</td><td>10</td><td>12</td></tr> <tr><td>Score 1</td><td colspan="3">6</td></tr> </table> Tinggi C & Durasi I <table border="1" style="width: 100%; border-collapse: collapse;"> <tr><th>C1</th><th>C2</th><th>C3</th></tr> <tr><td>I1</td><td>2</td><td>4</td><td>6</td></tr> <tr><td>I2</td><td>4</td><td>6</td><td>8</td></tr> <tr><td>I3</td><td>6</td><td>8</td><td>10</td></tr> <tr><td>Score 2</td><td colspan="3">6</td></tr> </table> Durasi I & Beban H <table border="1" style="width: 100%; border-collapse: collapse;"> <tr><th>I1</th><th>I2</th><th>I3</th></tr> <tr><td>H1</td><td>2</td><td>4</td><td>6</td></tr> <tr><td>H2</td><td>4</td><td>6</td><td>8</td></tr> <tr><td>H3</td><td>6</td><td>8</td><td>10</td></tr> <tr><td>H4</td><td>8</td><td>10</td><td>12</td></tr> <tr><td>Score 3</td><td colspan="3">6</td></tr> </table> Frekuensi D & Beban H <table border="1" style="width: 100%; border-collapse: collapse;"> <tr><th>D1</th><th>D2</th><th>D3</th></tr> <tr><td>H1</td><td>2</td><td>4</td><td>6</td></tr> <tr><td>H2</td><td>4</td><td>6</td><td>8</td></tr> <tr><td>H3</td><td>6</td><td>8</td><td>10</td></tr> <tr><td>H4</td><td>8</td><td>10</td><td>12</td></tr> <tr><td>Score 4</td><td colspan="3">8</td></tr> </table> Frekuensi E & durasi I <table border="1" style="width: 100%; border-collapse: collapse;"> <tr><th>D1</th><th>D2</th><th>D3</th></tr> <tr><td>I1</td><td>2</td><td>4</td><td>6</td></tr> <tr><td>I2</td><td>4</td><td>6</td><td>8</td></tr> <tr><td>I3</td><td>6</td><td>8</td><td>10</td></tr> <tr><td>Score 5</td><td colspan="3">8</td></tr> </table> <p>Total skor tubuh/lengan = total skor 1 sampai 5 34</p>	C1	C2	C3	H1	2	4	6	H2	4	6	8	H3	6	8	10	H4	8	10	12	Score 1	6			C1	C2	C3	I1	2	4	6	I2	4	6	8	I3	6	8	10	Score 2	6			I1	I2	I3	H1	2	4	6	H2	4	6	8	H3	6	8	10	H4	8	10	12	Score 3	6			D1	D2	D3	H1	2	4	6	H2	4	6	8	H3	6	8	10	H4	8	10	12	Score 4	8			D1	D2	D3	I1	2	4	6	I2	4	6	8	I3	6	8	10	Score 5	8			Pergelangan tangan Gerakan Berulang F & Kekuatan J <table border="1" style="width: 100%; border-collapse: collapse;"> <tr><th>F1</th><th>F2</th><th>F3</th></tr> <tr><td>J1</td><td>2</td><td>4</td><td>6</td></tr> <tr><td>J2</td><td>4</td><td>6</td><td>8</td></tr> <tr><td>J3</td><td>6</td><td>8</td><td>10</td></tr> <tr><td>J4</td><td>8</td><td>10</td><td>12</td></tr> <tr><td>Score 1</td><td colspan="3">10</td></tr> </table> Gerakan Berulang F & Durasi I <table border="1" style="width: 100%; border-collapse: collapse;"> <tr><th>F1</th><th>F2</th><th>F3</th></tr> <tr><td>I1</td><td>2</td><td>4</td><td>6</td></tr> <tr><td>I2</td><td>4</td><td>6</td><td>8</td></tr> <tr><td>I3</td><td>6</td><td>8</td><td>10</td></tr> <tr><td>Score 2</td><td colspan="3">6</td></tr> </table> Durasi I & Kekuatan J <table border="1" style="width: 100%; border-collapse: collapse;"> <tr><th>I1</th><th>I2</th><th>I3</th></tr> <tr><td>J1</td><td>2</td><td>4</td><td>6</td></tr> <tr><td>J2</td><td>4</td><td>6</td><td>8</td></tr> <tr><td>J3</td><td>6</td><td>8</td><td>10</td></tr> <tr><td>J4</td><td>8</td><td>10</td><td>12</td></tr> <tr><td>Score 3</td><td colspan="3">10</td></tr> </table> Posisi pergelangan tangan E & Kekuatan J <table border="1" style="width: 100%; border-collapse: collapse;"> <tr><th>E1</th><th>E2</th></tr> <tr><td>J1</td><td>2</td><td>4</td></tr> <tr><td>J2</td><td>4</td><td>6</td></tr> <tr><td>J3</td><td>6</td><td>8</td></tr> <tr><td>J4</td><td>8</td><td>10</td></tr> <tr><td>Score 4</td><td colspan="2">10</td></tr> </table> Posisi pergelangan tangan E & durasi I <table border="1" style="width: 100%; border-collapse: collapse;"> <tr><th>E1</th><th>E2</th></tr> <tr><td>I1</td><td>2</td><td>4</td></tr> <tr><td>I2</td><td>4</td><td>6</td></tr> <tr><td>I3</td><td>6</td><td>8</td></tr> <tr><td>Score 5</td><td colspan="2">6</td></tr> </table> <p>Total skor pergelangan tangan = total skor 1 sampai 5 42</p>	F1	F2	F3	J1	2	4	6	J2	4	6	8	J3	6	8	10	J4	8	10	12	Score 1	10			F1	F2	F3	I1	2	4	6	I2	4	6	8	I3	6	8	10	Score 2	6			I1	I2	I3	J1	2	4	6	J2	4	6	8	J3	6	8	10	J4	8	10	12	Score 3	10			E1	E2	J1	2	4	J2	4	6	J3	6	8	J4	8	10	Score 4	10		E1	E2	I1	2	4	I2	4	6	I3	6	8	Score 5	6		leher Posisi Leher G & Durasi I <table border="1" style="width: 100%; border-collapse: collapse;"> <tr><th>G1</th><th>G2</th><th>G3</th></tr> <tr><td>I1</td><td>2</td><td>4</td><td>6</td></tr> <tr><td>I2</td><td>4</td><td>6</td><td>8</td></tr> <tr><td>I3</td><td>6</td><td>8</td><td>10</td></tr> <tr><td>Score 1</td><td colspan="3">8</td></tr> </table> Kebutuhan Visual K & Durasi I <table border="1" style="width: 100%; border-collapse: collapse;"> <tr><th>K1</th><th>K2</th><th>K3</th></tr> <tr><td>I1</td><td>2</td><td>4</td><td>6</td></tr> <tr><td>I2</td><td>4</td><td>6</td><td>8</td></tr> <tr><td>I3</td><td>6</td><td>8</td><td>10</td></tr> <tr><td>Score 2</td><td colspan="3">8</td></tr> </table> <p>Total skor pergelangan tangan = total skor 1 sampai 2 16</p> Dasar Kestabilan <table border="1" style="width: 100%; border-collapse: collapse;"> <tr><th>L1</th><th>L2</th><th>L3</th></tr> <tr><td>I1</td><td>4</td><td>9</td></tr> <tr><td>Total Kestabilan</td><td colspan="2">4</td></tr> </table> Proses Bekerja <table border="1" style="width: 100%; border-collapse: collapse;"> <tr><th>M1</th><th>M2</th><th>M3</th></tr> <tr><td>I1</td><td>4</td><td>9</td></tr> <tr><td>Total Proses Bekerja</td><td colspan="2">4</td></tr> </table> Getaran <table border="1" style="width: 100%; border-collapse: collapse;"> <tr><th>N1</th><th>N2</th><th>N3</th></tr> <tr><td>I1</td><td>4</td><td>9</td></tr> <tr><td>Total Getaran</td><td colspan="2">1</td></tr> </table> Stress Kerja <table border="1" style="width: 100%; border-collapse: collapse;"> <tr><th>O1</th><th>O2</th><th>O3</th><th>O4</th></tr> <tr><td>I1</td><td>4</td><td>9</td><td>16</td></tr> <tr><td>Total stress kerja</td><td colspan="3">4</td></tr> </table>	G1	G2	G3	I1	2	4	6	I2	4	6	8	I3	6	8	10	Score 1	8			K1	K2	K3	I1	2	4	6	I2	4	6	8	I3	6	8	10	Score 2	8			L1	L2	L3	I1	4	9	Total Kestabilan	4		M1	M2	M3	I1	4	9	Total Proses Bekerja	4		N1	N2	N3	I1	4	9	Total Getaran	1		O1	O2	O3	O4	I1	4	9	16	Total stress kerja	4		
A1	A2	A3																																																																																																																																																																																																																																																																																																																																																																																																																		
H1	2	4	6																																																																																																																																																																																																																																																																																																																																																																																																																	
H2	4	6	8																																																																																																																																																																																																																																																																																																																																																																																																																	
H3	6	8	10																																																																																																																																																																																																																																																																																																																																																																																																																	
H4	8	10	12																																																																																																																																																																																																																																																																																																																																																																																																																	
Score 1	3																																																																																																																																																																																																																																																																																																																																																																																																																			
A1	A2	A3																																																																																																																																																																																																																																																																																																																																																																																																																		
I1	2	4	6																																																																																																																																																																																																																																																																																																																																																																																																																	
I2	4	6	8																																																																																																																																																																																																																																																																																																																																																																																																																	
I3	6	8	10																																																																																																																																																																																																																																																																																																																																																																																																																	
Score 2	3																																																																																																																																																																																																																																																																																																																																																																																																																			
I1	I2	I3																																																																																																																																																																																																																																																																																																																																																																																																																		
H1	2	4	6																																																																																																																																																																																																																																																																																																																																																																																																																	
H2	4	6	8																																																																																																																																																																																																																																																																																																																																																																																																																	
H3	6	8	10																																																																																																																																																																																																																																																																																																																																																																																																																	
H4	8	10	12																																																																																																																																																																																																																																																																																																																																																																																																																	
Score 3	6																																																																																																																																																																																																																																																																																																																																																																																																																			
B1	B2																																																																																																																																																																																																																																																																																																																																																																																																																			
E1	2	4																																																																																																																																																																																																																																																																																																																																																																																																																		
E2	4	6																																																																																																																																																																																																																																																																																																																																																																																																																		
E3	6	8																																																																																																																																																																																																																																																																																																																																																																																																																		
Score 4	3																																																																																																																																																																																																																																																																																																																																																																																																																			
B3	B4	B5																																																																																																																																																																																																																																																																																																																																																																																																																		
H1	2	4	6																																																																																																																																																																																																																																																																																																																																																																																																																	
H2	4	6	8																																																																																																																																																																																																																																																																																																																																																																																																																	
H3	6	8	10																																																																																																																																																																																																																																																																																																																																																																																																																	
H4	8	10	12																																																																																																																																																																																																																																																																																																																																																																																																																	
Score 5	6																																																																																																																																																																																																																																																																																																																																																																																																																			
B3	B4	B5																																																																																																																																																																																																																																																																																																																																																																																																																		
I1	2	4	6																																																																																																																																																																																																																																																																																																																																																																																																																	
I2	4	6	8																																																																																																																																																																																																																																																																																																																																																																																																																	
I3	6	8	10																																																																																																																																																																																																																																																																																																																																																																																																																	
Score 6	6																																																																																																																																																																																																																																																																																																																																																																																																																			
C1	C2	C3																																																																																																																																																																																																																																																																																																																																																																																																																		
H1	2	4	6																																																																																																																																																																																																																																																																																																																																																																																																																	
H2	4	6	8																																																																																																																																																																																																																																																																																																																																																																																																																	
H3	6	8	10																																																																																																																																																																																																																																																																																																																																																																																																																	
H4	8	10	12																																																																																																																																																																																																																																																																																																																																																																																																																	
Score 1	6																																																																																																																																																																																																																																																																																																																																																																																																																			
C1	C2	C3																																																																																																																																																																																																																																																																																																																																																																																																																		
I1	2	4	6																																																																																																																																																																																																																																																																																																																																																																																																																	
I2	4	6	8																																																																																																																																																																																																																																																																																																																																																																																																																	
I3	6	8	10																																																																																																																																																																																																																																																																																																																																																																																																																	
Score 2	6																																																																																																																																																																																																																																																																																																																																																																																																																			
I1	I2	I3																																																																																																																																																																																																																																																																																																																																																																																																																		
H1	2	4	6																																																																																																																																																																																																																																																																																																																																																																																																																	
H2	4	6	8																																																																																																																																																																																																																																																																																																																																																																																																																	
H3	6	8	10																																																																																																																																																																																																																																																																																																																																																																																																																	
H4	8	10	12																																																																																																																																																																																																																																																																																																																																																																																																																	
Score 3	6																																																																																																																																																																																																																																																																																																																																																																																																																			
D1	D2	D3																																																																																																																																																																																																																																																																																																																																																																																																																		
H1	2	4	6																																																																																																																																																																																																																																																																																																																																																																																																																	
H2	4	6	8																																																																																																																																																																																																																																																																																																																																																																																																																	
H3	6	8	10																																																																																																																																																																																																																																																																																																																																																																																																																	
H4	8	10	12																																																																																																																																																																																																																																																																																																																																																																																																																	
Score 4	8																																																																																																																																																																																																																																																																																																																																																																																																																			
D1	D2	D3																																																																																																																																																																																																																																																																																																																																																																																																																		
I1	2	4	6																																																																																																																																																																																																																																																																																																																																																																																																																	
I2	4	6	8																																																																																																																																																																																																																																																																																																																																																																																																																	
I3	6	8	10																																																																																																																																																																																																																																																																																																																																																																																																																	
Score 5	8																																																																																																																																																																																																																																																																																																																																																																																																																			
F1	F2	F3																																																																																																																																																																																																																																																																																																																																																																																																																		
J1	2	4	6																																																																																																																																																																																																																																																																																																																																																																																																																	
J2	4	6	8																																																																																																																																																																																																																																																																																																																																																																																																																	
J3	6	8	10																																																																																																																																																																																																																																																																																																																																																																																																																	
J4	8	10	12																																																																																																																																																																																																																																																																																																																																																																																																																	
Score 1	10																																																																																																																																																																																																																																																																																																																																																																																																																			
F1	F2	F3																																																																																																																																																																																																																																																																																																																																																																																																																		
I1	2	4	6																																																																																																																																																																																																																																																																																																																																																																																																																	
I2	4	6	8																																																																																																																																																																																																																																																																																																																																																																																																																	
I3	6	8	10																																																																																																																																																																																																																																																																																																																																																																																																																	
Score 2	6																																																																																																																																																																																																																																																																																																																																																																																																																			
I1	I2	I3																																																																																																																																																																																																																																																																																																																																																																																																																		
J1	2	4	6																																																																																																																																																																																																																																																																																																																																																																																																																	
J2	4	6	8																																																																																																																																																																																																																																																																																																																																																																																																																	
J3	6	8	10																																																																																																																																																																																																																																																																																																																																																																																																																	
J4	8	10	12																																																																																																																																																																																																																																																																																																																																																																																																																	
Score 3	10																																																																																																																																																																																																																																																																																																																																																																																																																			
E1	E2																																																																																																																																																																																																																																																																																																																																																																																																																			
J1	2	4																																																																																																																																																																																																																																																																																																																																																																																																																		
J2	4	6																																																																																																																																																																																																																																																																																																																																																																																																																		
J3	6	8																																																																																																																																																																																																																																																																																																																																																																																																																		
J4	8	10																																																																																																																																																																																																																																																																																																																																																																																																																		
Score 4	10																																																																																																																																																																																																																																																																																																																																																																																																																			
E1	E2																																																																																																																																																																																																																																																																																																																																																																																																																			
I1	2	4																																																																																																																																																																																																																																																																																																																																																																																																																		
I2	4	6																																																																																																																																																																																																																																																																																																																																																																																																																		
I3	6	8																																																																																																																																																																																																																																																																																																																																																																																																																		
Score 5	6																																																																																																																																																																																																																																																																																																																																																																																																																			
G1	G2	G3																																																																																																																																																																																																																																																																																																																																																																																																																		
I1	2	4	6																																																																																																																																																																																																																																																																																																																																																																																																																	
I2	4	6	8																																																																																																																																																																																																																																																																																																																																																																																																																	
I3	6	8	10																																																																																																																																																																																																																																																																																																																																																																																																																	
Score 1	8																																																																																																																																																																																																																																																																																																																																																																																																																			
K1	K2	K3																																																																																																																																																																																																																																																																																																																																																																																																																		
I1	2	4	6																																																																																																																																																																																																																																																																																																																																																																																																																	
I2	4	6	8																																																																																																																																																																																																																																																																																																																																																																																																																	
I3	6	8	10																																																																																																																																																																																																																																																																																																																																																																																																																	
Score 2	8																																																																																																																																																																																																																																																																																																																																																																																																																			
L1	L2	L3																																																																																																																																																																																																																																																																																																																																																																																																																		
I1	4	9																																																																																																																																																																																																																																																																																																																																																																																																																		
Total Kestabilan	4																																																																																																																																																																																																																																																																																																																																																																																																																			
M1	M2	M3																																																																																																																																																																																																																																																																																																																																																																																																																		
I1	4	9																																																																																																																																																																																																																																																																																																																																																																																																																		
Total Proses Bekerja	4																																																																																																																																																																																																																																																																																																																																																																																																																			
N1	N2	N3																																																																																																																																																																																																																																																																																																																																																																																																																		
I1	4	9																																																																																																																																																																																																																																																																																																																																																																																																																		
Total Getaran	1																																																																																																																																																																																																																																																																																																																																																																																																																			
O1	O2	O3	O4																																																																																																																																																																																																																																																																																																																																																																																																																	
I1	4	9	16																																																																																																																																																																																																																																																																																																																																																																																																																	
Total stress kerja	4																																																																																																																																																																																																																																																																																																																																																																																																																			

Gambar 7 Rekapitulasi Kuisioner

Rekapitulasi kuisioner pengamat dan rekapitulasi kuisioner operator. Ditemukan bahwa pada bagian tubuh punggung mendapatkan skor 34, pada bagian tubuh bahu/lengan mendapatkan skor 34, pada bagian tubuh pergelangan tangan 42, pada bagian tubuh leher mendapatkan skor 16, pada dasar kestabilan beban kerja didapatkan skor 4, pada beban proses kerja mendapatkan nilai skor 4, pada beban proses getaran mendapatka nilai 1, dan pada stress beban kerja mendapatkan skor 4. Jika keseluruhan skor dijumlahkan maka mendapatkan skor 139. Setelah itu akan dihitung untuk mencari skor E.

$$E(\%) \frac{X}{X_{max}} \times 100\% =$$

$$E(\%) \frac{139}{176} \times 100\% = 78,97\%$$

Tabel 9 Kategori Skor QEC

QEC score (E)	Aksi
≤ 40%	Bisa Diterima
41-50%	Penyelidikan lebih lanjut
51-70%	Penyelidikan lebih lanjut dan dilakukan perbaikan segera
> 70%	Penyelidikan lebih lanjut dan dilakukan perbaikan sekarang juga

Pada tabel kategori diatas ditemukan bahwa pada proses pengelasan mendapatkan nilai 78,97%, nilai tersebut termasuk dalam kategori resiko sangat tinggi dan perlu dilakukan perbaikan saat ini juga.

f. Operator Perakitan

EXPOSURE SCORE	NAMA PEKERJA: Supnyanto	TANGGAL :	PEKERJAAN : Perakitan																																																																																																																																																																																																																																																																																																																																																																																																																																																											
Punggung Posisi Punggung A & Beban H <table border="1"> <tr><td></td><td>A1</td><td>A2</td><td>A3</td></tr> <tr><td>H1</td><td>2</td><td>4</td><td>6</td></tr> <tr><td>H2</td><td>4</td><td>6</td><td>8</td></tr> <tr><td>H3</td><td>6</td><td>8</td><td>10</td></tr> <tr><td>H4</td><td>8</td><td>10</td><td>12</td></tr> <tr><td>Score 1</td><td colspan="3">4</td></tr> </table> Posisi Punggung A & Durasi I <table border="1"> <tr><td></td><td>A1</td><td>A2</td><td>A3</td></tr> <tr><td>I1</td><td>2</td><td>4</td><td>6</td></tr> <tr><td>I2</td><td>4</td><td>6</td><td>8</td></tr> <tr><td>I3</td><td>6</td><td>8</td><td>10</td></tr> <tr><td>Score 2</td><td colspan="3">4</td></tr> </table> Posisi Durasi I & Beban H <table border="1"> <tr><td></td><td>I1</td><td>I2</td><td>I3</td></tr> <tr><td>H1</td><td>2</td><td>4</td><td>6</td></tr> <tr><td>H2</td><td>4</td><td>6</td><td>8</td></tr> <tr><td>H3</td><td>6</td><td>8</td><td>10</td></tr> <tr><td>H4</td><td>8</td><td>10</td><td>12</td></tr> <tr><td>Score 3</td><td colspan="3">2</td></tr> </table> Posisi Statis B & Durasi I <table border="1"> <tr><td></td><td>B1</td><td>B2</td></tr> <tr><td>I1</td><td>2</td><td>4</td></tr> <tr><td>I2</td><td>4</td><td>6</td></tr> <tr><td>I3</td><td>6</td><td>8</td></tr> <tr><td>Score 4</td><td colspan="2">4</td></tr> </table> Frekuensi B & Beban H <table border="1"> <tr><td></td><td>B3</td><td>B4</td><td>B5</td></tr> <tr><td>H1</td><td>2</td><td>4</td><td>6</td></tr> <tr><td>H2</td><td>4</td><td>6</td><td>8</td></tr> <tr><td>H3</td><td>6</td><td>8</td><td>10</td></tr> <tr><td>H4</td><td>8</td><td>10</td><td>12</td></tr> <tr><td>Score 5</td><td colspan="3">4</td></tr> </table> Frekuensi B & durasi I <table border="1"> <tr><td></td><td>B3</td><td>B4</td><td>B5</td></tr> <tr><td>I1</td><td>2</td><td>4</td><td>6</td></tr> <tr><td>I2</td><td>4</td><td>6</td><td>8</td></tr> <tr><td>I3</td><td>6</td><td>8</td><td>10</td></tr> <tr><td>Score 6</td><td colspan="3">4</td></tr> </table> <p>Totol skor punggung = total skor 1 sampai 4 atau total skor 1 sampai 3 ditambah 5&6 14</p>		A1	A2	A3	H1	2	4	6	H2	4	6	8	H3	6	8	10	H4	8	10	12	Score 1	4				A1	A2	A3	I1	2	4	6	I2	4	6	8	I3	6	8	10	Score 2	4				I1	I2	I3	H1	2	4	6	H2	4	6	8	H3	6	8	10	H4	8	10	12	Score 3	2				B1	B2	I1	2	4	I2	4	6	I3	6	8	Score 4	4			B3	B4	B5	H1	2	4	6	H2	4	6	8	H3	6	8	10	H4	8	10	12	Score 5	4				B3	B4	B5	I1	2	4	6	I2	4	6	8	I3	6	8	10	Score 6	4			Bahu/Lengan Tinggi C & Beban H <table border="1"> <tr><td></td><td>C1</td><td>C2</td><td>C3</td></tr> <tr><td>H1</td><td>2</td><td>4</td><td>6</td></tr> <tr><td>H2</td><td>4</td><td>6</td><td>8</td></tr> <tr><td>H3</td><td>6</td><td>8</td><td>10</td></tr> <tr><td>H4</td><td>8</td><td>10</td><td>12</td></tr> <tr><td>Score 1</td><td colspan="3">2</td></tr> </table> Tinggi C & Durasi I <table border="1"> <tr><td></td><td>C1</td><td>C2</td><td>C3</td></tr> <tr><td>I1</td><td>2</td><td>4</td><td>6</td></tr> <tr><td>I2</td><td>4</td><td>6</td><td>8</td></tr> <tr><td>I3</td><td>6</td><td>8</td><td>10</td></tr> <tr><td>Score 2</td><td colspan="3">2</td></tr> </table> Durasi I & Beban H <table border="1"> <tr><td></td><td>I1</td><td>I2</td><td>I3</td></tr> <tr><td>H1</td><td>2</td><td>4</td><td>6</td></tr> <tr><td>H2</td><td>4</td><td>6</td><td>8</td></tr> <tr><td>H3</td><td>6</td><td>8</td><td>10</td></tr> <tr><td>H4</td><td>8</td><td>10</td><td>12</td></tr> <tr><td>Score 3</td><td colspan="3">2</td></tr> </table> Frekuensi D & Beban H <table border="1"> <tr><td></td><td>D1</td><td>D2</td><td>D3</td></tr> <tr><td>H1</td><td>2</td><td>4</td><td>6</td></tr> <tr><td>H2</td><td>4</td><td>6</td><td>8</td></tr> <tr><td>H3</td><td>6</td><td>8</td><td>10</td></tr> <tr><td>H4</td><td>8</td><td>10</td><td>12</td></tr> <tr><td>Score 4</td><td colspan="3">4</td></tr> </table> Frekuensi D & durasi I <table border="1"> <tr><td></td><td>D1</td><td>D2</td><td>D3</td></tr> <tr><td>I1</td><td>2</td><td>4</td><td>6</td></tr> <tr><td>I2</td><td>4</td><td>6</td><td>8</td></tr> <tr><td>I3</td><td>6</td><td>8</td><td>10</td></tr> <tr><td>Score 5</td><td colspan="3">4</td></tr> </table> <p>Totol skor bahu/lengan = total skor 1 sampai 5 14</p>		C1	C2	C3	H1	2	4	6	H2	4	6	8	H3	6	8	10	H4	8	10	12	Score 1	2				C1	C2	C3	I1	2	4	6	I2	4	6	8	I3	6	8	10	Score 2	2				I1	I2	I3	H1	2	4	6	H2	4	6	8	H3	6	8	10	H4	8	10	12	Score 3	2				D1	D2	D3	H1	2	4	6	H2	4	6	8	H3	6	8	10	H4	8	10	12	Score 4	4				D1	D2	D3	I1	2	4	6	I2	4	6	8	I3	6	8	10	Score 5	4			Pergelangan tangan Gerakan Berulang F & Kekuatan J <table border="1"> <tr><td></td><td>F1</td><td>F2</td><td>F3</td></tr> <tr><td>J1</td><td>2</td><td>4</td><td>6</td></tr> <tr><td>J2</td><td>4</td><td>6</td><td>8</td></tr> <tr><td>J3</td><td>6</td><td>8</td><td>10</td></tr> <tr><td>J4</td><td>8</td><td>10</td><td>12</td></tr> <tr><td>Score 1</td><td colspan="3">4</td></tr> </table> Gerakan Berulang F & Durasi I <table border="1"> <tr><td></td><td>F1</td><td>F2</td><td>F3</td></tr> <tr><td>I1</td><td>2</td><td>4</td><td>6</td></tr> <tr><td>I2</td><td>4</td><td>6</td><td>8</td></tr> <tr><td>I3</td><td>6</td><td>8</td><td>10</td></tr> <tr><td>Score 2</td><td colspan="3">2</td></tr> </table> Durasi I & Kekuatan J <table border="1"> <tr><td></td><td>I1</td><td>I2</td><td>I3</td></tr> <tr><td>J1</td><td>2</td><td>4</td><td>6</td></tr> <tr><td>J2</td><td>4</td><td>6</td><td>8</td></tr> <tr><td>J3</td><td>6</td><td>8</td><td>10</td></tr> <tr><td>J4</td><td>8</td><td>10</td><td>12</td></tr> <tr><td>Score 3</td><td colspan="3">4</td></tr> </table> Posisi pergelangan tangan E & Kekuatan J <table border="1"> <tr><td></td><td>E1</td><td>E2</td></tr> <tr><td>J1</td><td>2</td><td>4</td></tr> <tr><td>J2</td><td>4</td><td>6</td></tr> <tr><td>J3</td><td>6</td><td>8</td></tr> <tr><td>J4</td><td>8</td><td>10</td></tr> <tr><td>Score 4</td><td colspan="2">6</td></tr> </table> Posisi pergelangan tangan E & durasi I <table border="1"> <tr><td></td><td>E1</td><td>E2</td></tr> <tr><td>I1</td><td>2</td><td>4</td></tr> <tr><td>I2</td><td>4</td><td>6</td></tr> <tr><td>I3</td><td>6</td><td>8</td></tr> <tr><td>Score 5</td><td colspan="2">4</td></tr> </table> <p>Totol skor pergelangan tangan = total skor 1 sampai 5 20</p>		F1	F2	F3	J1	2	4	6	J2	4	6	8	J3	6	8	10	J4	8	10	12	Score 1	4				F1	F2	F3	I1	2	4	6	I2	4	6	8	I3	6	8	10	Score 2	2				I1	I2	I3	J1	2	4	6	J2	4	6	8	J3	6	8	10	J4	8	10	12	Score 3	4				E1	E2	J1	2	4	J2	4	6	J3	6	8	J4	8	10	Score 4	6			E1	E2	I1	2	4	I2	4	6	I3	6	8	Score 5	4		Leher Posisi Leher G & Durasi I <table border="1"> <tr><td></td><td>G1</td><td>G2</td><td>G3</td></tr> <tr><td>I1</td><td>2</td><td>4</td><td>6</td></tr> <tr><td>I2</td><td>4</td><td>6</td><td>8</td></tr> <tr><td>I3</td><td>6</td><td>8</td><td>10</td></tr> <tr><td>Score 1</td><td colspan="3">4</td></tr> </table> Kebutuhan Visual K & Durasi I <table border="1"> <tr><td></td><td>K1</td><td>K2</td><td>K3</td></tr> <tr><td>I1</td><td>2</td><td>4</td><td>6</td></tr> <tr><td>I2</td><td>4</td><td>6</td><td>8</td></tr> <tr><td>I3</td><td>6</td><td>8</td><td>10</td></tr> <tr><td>Score 2</td><td colspan="3">4</td></tr> </table> <p>Totol skor pergelangan tangan = total skor 1 sampai 2 8</p> Dasar Kestabilan <table border="1"> <tr><td></td><td>L1</td><td>L2</td><td>L3</td></tr> <tr><td>T</td><td>4</td><td>9</td><td></td></tr> <tr><td>Total</td><td colspan="2">1</td><td></td></tr> <tr><td>Kestabilan</td><td colspan="2">1</td><td></td></tr> </table> Proses Bekerja <table border="1"> <tr><td></td><td>M1</td><td>M2</td><td>M3</td></tr> <tr><td>T</td><td>4</td><td>9</td><td></td></tr> <tr><td>Total</td><td colspan="2">1</td><td></td></tr> <tr><td>Proses Bekerja</td><td colspan="2">1</td><td></td></tr> </table> Getaran <table border="1"> <tr><td></td><td>N1</td><td>N2</td><td>N3</td></tr> <tr><td>T</td><td>4</td><td>9</td><td></td></tr> <tr><td>Total</td><td colspan="2">1</td><td></td></tr> <tr><td>Getaran</td><td colspan="2">1</td><td></td></tr> </table> Sitres Kerja Akibat Keluhan <table border="1"> <tr><td></td><td>O1</td><td>O2</td><td>O3</td><td>O4</td></tr> <tr><td>T</td><td>4</td><td>9</td><td>16</td><td></td></tr> <tr><td>Total stress kerja</td><td colspan="3">1</td><td></td></tr> </table>		G1	G2	G3	I1	2	4	6	I2	4	6	8	I3	6	8	10	Score 1	4				K1	K2	K3	I1	2	4	6	I2	4	6	8	I3	6	8	10	Score 2	4				L1	L2	L3	T	4	9		Total	1			Kestabilan	1				M1	M2	M3	T	4	9		Total	1			Proses Bekerja	1				N1	N2	N3	T	4	9		Total	1			Getaran	1				O1	O2	O3	O4	T	4	9	16		Total stress kerja	1			
	A1	A2	A3																																																																																																																																																																																																																																																																																																																																																																																																																																																											
H1	2	4	6																																																																																																																																																																																																																																																																																																																																																																																																																																																											
H2	4	6	8																																																																																																																																																																																																																																																																																																																																																																																																																																																											
H3	6	8	10																																																																																																																																																																																																																																																																																																																																																																																																																																																											
H4	8	10	12																																																																																																																																																																																																																																																																																																																																																																																																																																																											
Score 1	4																																																																																																																																																																																																																																																																																																																																																																																																																																																													
	A1	A2	A3																																																																																																																																																																																																																																																																																																																																																																																																																																																											
I1	2	4	6																																																																																																																																																																																																																																																																																																																																																																																																																																																											
I2	4	6	8																																																																																																																																																																																																																																																																																																																																																																																																																																																											
I3	6	8	10																																																																																																																																																																																																																																																																																																																																																																																																																																																											
Score 2	4																																																																																																																																																																																																																																																																																																																																																																																																																																																													
	I1	I2	I3																																																																																																																																																																																																																																																																																																																																																																																																																																																											
H1	2	4	6																																																																																																																																																																																																																																																																																																																																																																																																																																																											
H2	4	6	8																																																																																																																																																																																																																																																																																																																																																																																																																																																											
H3	6	8	10																																																																																																																																																																																																																																																																																																																																																																																																																																																											
H4	8	10	12																																																																																																																																																																																																																																																																																																																																																																																																																																																											
Score 3	2																																																																																																																																																																																																																																																																																																																																																																																																																																																													
	B1	B2																																																																																																																																																																																																																																																																																																																																																																																																																																																												
I1	2	4																																																																																																																																																																																																																																																																																																																																																																																																																																																												
I2	4	6																																																																																																																																																																																																																																																																																																																																																																																																																																																												
I3	6	8																																																																																																																																																																																																																																																																																																																																																																																																																																																												
Score 4	4																																																																																																																																																																																																																																																																																																																																																																																																																																																													
	B3	B4	B5																																																																																																																																																																																																																																																																																																																																																																																																																																																											
H1	2	4	6																																																																																																																																																																																																																																																																																																																																																																																																																																																											
H2	4	6	8																																																																																																																																																																																																																																																																																																																																																																																																																																																											
H3	6	8	10																																																																																																																																																																																																																																																																																																																																																																																																																																																											
H4	8	10	12																																																																																																																																																																																																																																																																																																																																																																																																																																																											
Score 5	4																																																																																																																																																																																																																																																																																																																																																																																																																																																													
	B3	B4	B5																																																																																																																																																																																																																																																																																																																																																																																																																																																											
I1	2	4	6																																																																																																																																																																																																																																																																																																																																																																																																																																																											
I2	4	6	8																																																																																																																																																																																																																																																																																																																																																																																																																																																											
I3	6	8	10																																																																																																																																																																																																																																																																																																																																																																																																																																																											
Score 6	4																																																																																																																																																																																																																																																																																																																																																																																																																																																													
	C1	C2	C3																																																																																																																																																																																																																																																																																																																																																																																																																																																											
H1	2	4	6																																																																																																																																																																																																																																																																																																																																																																																																																																																											
H2	4	6	8																																																																																																																																																																																																																																																																																																																																																																																																																																																											
H3	6	8	10																																																																																																																																																																																																																																																																																																																																																																																																																																																											
H4	8	10	12																																																																																																																																																																																																																																																																																																																																																																																																																																																											
Score 1	2																																																																																																																																																																																																																																																																																																																																																																																																																																																													
	C1	C2	C3																																																																																																																																																																																																																																																																																																																																																																																																																																																											
I1	2	4	6																																																																																																																																																																																																																																																																																																																																																																																																																																																											
I2	4	6	8																																																																																																																																																																																																																																																																																																																																																																																																																																																											
I3	6	8	10																																																																																																																																																																																																																																																																																																																																																																																																																																																											
Score 2	2																																																																																																																																																																																																																																																																																																																																																																																																																																																													
	I1	I2	I3																																																																																																																																																																																																																																																																																																																																																																																																																																																											
H1	2	4	6																																																																																																																																																																																																																																																																																																																																																																																																																																																											
H2	4	6	8																																																																																																																																																																																																																																																																																																																																																																																																																																																											
H3	6	8	10																																																																																																																																																																																																																																																																																																																																																																																																																																																											
H4	8	10	12																																																																																																																																																																																																																																																																																																																																																																																																																																																											
Score 3	2																																																																																																																																																																																																																																																																																																																																																																																																																																																													
	D1	D2	D3																																																																																																																																																																																																																																																																																																																																																																																																																																																											
H1	2	4	6																																																																																																																																																																																																																																																																																																																																																																																																																																																											
H2	4	6	8																																																																																																																																																																																																																																																																																																																																																																																																																																																											
H3	6	8	10																																																																																																																																																																																																																																																																																																																																																																																																																																																											
H4	8	10	12																																																																																																																																																																																																																																																																																																																																																																																																																																																											
Score 4	4																																																																																																																																																																																																																																																																																																																																																																																																																																																													
	D1	D2	D3																																																																																																																																																																																																																																																																																																																																																																																																																																																											
I1	2	4	6																																																																																																																																																																																																																																																																																																																																																																																																																																																											
I2	4	6	8																																																																																																																																																																																																																																																																																																																																																																																																																																																											
I3	6	8	10																																																																																																																																																																																																																																																																																																																																																																																																																																																											
Score 5	4																																																																																																																																																																																																																																																																																																																																																																																																																																																													
	F1	F2	F3																																																																																																																																																																																																																																																																																																																																																																																																																																																											
J1	2	4	6																																																																																																																																																																																																																																																																																																																																																																																																																																																											
J2	4	6	8																																																																																																																																																																																																																																																																																																																																																																																																																																																											
J3	6	8	10																																																																																																																																																																																																																																																																																																																																																																																																																																																											
J4	8	10	12																																																																																																																																																																																																																																																																																																																																																																																																																																																											
Score 1	4																																																																																																																																																																																																																																																																																																																																																																																																																																																													
	F1	F2	F3																																																																																																																																																																																																																																																																																																																																																																																																																																																											
I1	2	4	6																																																																																																																																																																																																																																																																																																																																																																																																																																																											
I2	4	6	8																																																																																																																																																																																																																																																																																																																																																																																																																																																											
I3	6	8	10																																																																																																																																																																																																																																																																																																																																																																																																																																																											
Score 2	2																																																																																																																																																																																																																																																																																																																																																																																																																																																													
	I1	I2	I3																																																																																																																																																																																																																																																																																																																																																																																																																																																											
J1	2	4	6																																																																																																																																																																																																																																																																																																																																																																																																																																																											
J2	4	6	8																																																																																																																																																																																																																																																																																																																																																																																																																																																											
J3	6	8	10																																																																																																																																																																																																																																																																																																																																																																																																																																																											
J4	8	10	12																																																																																																																																																																																																																																																																																																																																																																																																																																																											
Score 3	4																																																																																																																																																																																																																																																																																																																																																																																																																																																													
	E1	E2																																																																																																																																																																																																																																																																																																																																																																																																																																																												
J1	2	4																																																																																																																																																																																																																																																																																																																																																																																																																																																												
J2	4	6																																																																																																																																																																																																																																																																																																																																																																																																																																																												
J3	6	8																																																																																																																																																																																																																																																																																																																																																																																																																																																												
J4	8	10																																																																																																																																																																																																																																																																																																																																																																																																																																																												
Score 4	6																																																																																																																																																																																																																																																																																																																																																																																																																																																													
	E1	E2																																																																																																																																																																																																																																																																																																																																																																																																																																																												
I1	2	4																																																																																																																																																																																																																																																																																																																																																																																																																																																												
I2	4	6																																																																																																																																																																																																																																																																																																																																																																																																																																																												
I3	6	8																																																																																																																																																																																																																																																																																																																																																																																																																																																												
Score 5	4																																																																																																																																																																																																																																																																																																																																																																																																																																																													
	G1	G2	G3																																																																																																																																																																																																																																																																																																																																																																																																																																																											
I1	2	4	6																																																																																																																																																																																																																																																																																																																																																																																																																																																											
I2	4	6	8																																																																																																																																																																																																																																																																																																																																																																																																																																																											
I3	6	8	10																																																																																																																																																																																																																																																																																																																																																																																																																																																											
Score 1	4																																																																																																																																																																																																																																																																																																																																																																																																																																																													
	K1	K2	K3																																																																																																																																																																																																																																																																																																																																																																																																																																																											
I1	2	4	6																																																																																																																																																																																																																																																																																																																																																																																																																																																											
I2	4	6	8																																																																																																																																																																																																																																																																																																																																																																																																																																																											
I3	6	8	10																																																																																																																																																																																																																																																																																																																																																																																																																																																											
Score 2	4																																																																																																																																																																																																																																																																																																																																																																																																																																																													
	L1	L2	L3																																																																																																																																																																																																																																																																																																																																																																																																																																																											
T	4	9																																																																																																																																																																																																																																																																																																																																																																																																																																																												
Total	1																																																																																																																																																																																																																																																																																																																																																																																																																																																													
Kestabilan	1																																																																																																																																																																																																																																																																																																																																																																																																																																																													
	M1	M2	M3																																																																																																																																																																																																																																																																																																																																																																																																																																																											
T	4	9																																																																																																																																																																																																																																																																																																																																																																																																																																																												
Total	1																																																																																																																																																																																																																																																																																																																																																																																																																																																													
Proses Bekerja	1																																																																																																																																																																																																																																																																																																																																																																																																																																																													
	N1	N2	N3																																																																																																																																																																																																																																																																																																																																																																																																																																																											
T	4	9																																																																																																																																																																																																																																																																																																																																																																																																																																																												
Total	1																																																																																																																																																																																																																																																																																																																																																																																																																																																													
Getaran	1																																																																																																																																																																																																																																																																																																																																																																																																																																																													
	O1	O2	O3	O4																																																																																																																																																																																																																																																																																																																																																																																																																																																										
T	4	9	16																																																																																																																																																																																																																																																																																																																																																																																																																																																											
Total stress kerja	1																																																																																																																																																																																																																																																																																																																																																																																																																																																													

Gambar 8 Rekapitulasi Kuisisioner

Rekapitulasi kuisisioner pengamat dan rekapitulasi kuisisioner operator. Ditemukan bahwa pada bagian tubuh punggung mendapatkan skor 14, pada bagian tubuh bahu/lengan mendapatkan skor 14, pada bagian tubuh pergelangan tangan 20, pada bagian tubuh leher mendapatkan skor 8, pada dasar kestabilan beban kerja didapatkan skor 1, pada beban proses kerja mendapatkan nilai skor 1, pada beban proses getaran mendapkatka nilai 1, dan pada stress kerja akibat keluhan mendapatkan skor 1. Jika keseluruhan skor dijumlahkan maka mendapatkan skor 60. Setelah itu akan dihitung untuk mencari skor E.

$$E(\%) \frac{X}{X_{max}} \times 100\% =$$

$$E(\%) \frac{60}{176} \times 100\% = 37,18\%$$

Tabel 10 Kategori Skor QEC

QEC score (E)	Aksi
≤ 40%	Bisa Diterima
41-50%	Penyelidikan lebih lanjut
51-70%	Penyelidikan lebih lanjut dan dilakukan perbaikan segera
> 70%	Penyelidikan lebih lanjut dan dilakukan perbaikan sekarang juga

Pada tabel kategori diatas ditemukan bahwa pada proses perakitan mendapatkan nilai 35,18%, nilai tersebut termasuk dalam kategori resiko rendah dan tidak perlu dilakukan perbaikan.

g. Operator Pengecatan

Usulan Perbaikan Fasilitas Kerja pada Produksi Parutan Kelapa Berdasarkan...

EXPOSURE SCORE	NAMA PEKERJA: Rifa	TANGGAL :	PEKERJAAN : Pengecatan																																																																																								
Punggung	Bahu/Lengan	Pergelangan tangan	leher																																																																																								
Posisi Punggung A & Beban H	Tinggi C & Beban H	Gerakan Berulang F & Kekuatan J	Posisi Leher G & Durasi I																																																																																								
<table border="1"> <thead> <tr><th>A1</th><th>A2</th><th>A3</th></tr> </thead> <tbody> <tr><td>H1</td><td>2</td><td>4</td><td>6</td></tr> <tr><td>H2</td><td>4</td><td>6</td><td>8</td></tr> <tr><td>H3</td><td>6</td><td>8</td><td>10</td></tr> <tr><td>H4</td><td>8</td><td>10</td><td>12</td></tr> <tr><td>Score 1</td><td colspan="3">2</td></tr> </tbody> </table>	A1	A2	A3	H1	2	4	6	H2	4	6	8	H3	6	8	10	H4	8	10	12	Score 1	2			<table border="1"> <thead> <tr><th>C1</th><th>C2</th><th>C3</th></tr> </thead> <tbody> <tr><td>H1</td><td>2</td><td>4</td><td>6</td></tr> <tr><td>H2</td><td>4</td><td>6</td><td>8</td></tr> <tr><td>H3</td><td>6</td><td>8</td><td>10</td></tr> <tr><td>H4</td><td>8</td><td>10</td><td>12</td></tr> <tr><td>Score 1</td><td colspan="3">4</td></tr> </tbody> </table>	C1	C2	C3	H1	2	4	6	H2	4	6	8	H3	6	8	10	H4	8	10	12	Score 1	4			<table border="1"> <thead> <tr><th>F1</th><th>F2</th><th>F3</th></tr> </thead> <tbody> <tr><td>J1</td><td>2</td><td>4</td><td>6</td></tr> <tr><td>J2</td><td>4</td><td>6</td><td>8</td></tr> <tr><td>J3</td><td>6</td><td>8</td><td>10</td></tr> <tr><td>J4</td><td>8</td><td>10</td><td>12</td></tr> <tr><td>Score 1</td><td colspan="3">4</td></tr> </tbody> </table>	F1	F2	F3	J1	2	4	6	J2	4	6	8	J3	6	8	10	J4	8	10	12	Score 1	4			<table border="1"> <thead> <tr><th>G1</th><th>G2</th><th>G3</th></tr> </thead> <tbody> <tr><td>I1</td><td>2</td><td>4</td><td>6</td></tr> <tr><td>I2</td><td>4</td><td>6</td><td>8</td></tr> <tr><td>I3</td><td>6</td><td>8</td><td>10</td></tr> <tr><td>Score 1</td><td colspan="3">2</td></tr> </tbody> </table>	G1	G2	G3	I1	2	4	6	I2	4	6	8	I3	6	8	10	Score 1	2		
A1	A2	A3																																																																																									
H1	2	4	6																																																																																								
H2	4	6	8																																																																																								
H3	6	8	10																																																																																								
H4	8	10	12																																																																																								
Score 1	2																																																																																										
C1	C2	C3																																																																																									
H1	2	4	6																																																																																								
H2	4	6	8																																																																																								
H3	6	8	10																																																																																								
H4	8	10	12																																																																																								
Score 1	4																																																																																										
F1	F2	F3																																																																																									
J1	2	4	6																																																																																								
J2	4	6	8																																																																																								
J3	6	8	10																																																																																								
J4	8	10	12																																																																																								
Score 1	4																																																																																										
G1	G2	G3																																																																																									
I1	2	4	6																																																																																								
I2	4	6	8																																																																																								
I3	6	8	10																																																																																								
Score 1	2																																																																																										
Posisi Punggung A & Durasi I	Tinggi C & Durasi I	Gerakan Berulang F & Durasi I	Kebutuhan Visual K & Durasi I																																																																																								
<table border="1"> <thead> <tr><th>A1</th><th>A2</th><th>A3</th></tr> </thead> <tbody> <tr><td>I1</td><td>2</td><td>4</td><td>6</td></tr> <tr><td>I2</td><td>4</td><td>6</td><td>8</td></tr> <tr><td>I3</td><td>6</td><td>8</td><td>10</td></tr> <tr><td>Score 2</td><td colspan="3">2</td></tr> </tbody> </table>	A1	A2	A3	I1	2	4	6	I2	4	6	8	I3	6	8	10	Score 2	2			<table border="1"> <thead> <tr><th>C1</th><th>C2</th><th>C3</th></tr> </thead> <tbody> <tr><td>I1</td><td>2</td><td>4</td><td>6</td></tr> <tr><td>I2</td><td>4</td><td>6</td><td>8</td></tr> <tr><td>I3</td><td>6</td><td>8</td><td>10</td></tr> <tr><td>Score 2</td><td colspan="3">4</td></tr> </tbody> </table>	C1	C2	C3	I1	2	4	6	I2	4	6	8	I3	6	8	10	Score 2	4			<table border="1"> <thead> <tr><th>F1</th><th>F2</th><th>F3</th></tr> </thead> <tbody> <tr><td>I1</td><td>2</td><td>4</td><td>6</td></tr> <tr><td>I2</td><td>4</td><td>6</td><td>8</td></tr> <tr><td>I3</td><td>6</td><td>8</td><td>10</td></tr> <tr><td>Score 2</td><td colspan="3">2</td></tr> </tbody> </table>	F1	F2	F3	I1	2	4	6	I2	4	6	8	I3	6	8	10	Score 2	2			<table border="1"> <thead> <tr><th>K1</th><th>K2</th><th>K3</th></tr> </thead> <tbody> <tr><td>I1</td><td>2</td><td>4</td><td>6</td></tr> <tr><td>I2</td><td>4</td><td>6</td><td>8</td></tr> <tr><td>I3</td><td>6</td><td>8</td><td>10</td></tr> <tr><td>Score 2</td><td colspan="3">4</td></tr> </tbody> </table>	K1	K2	K3	I1	2	4	6	I2	4	6	8	I3	6	8	10	Score 2	4														
A1	A2	A3																																																																																									
I1	2	4	6																																																																																								
I2	4	6	8																																																																																								
I3	6	8	10																																																																																								
Score 2	2																																																																																										
C1	C2	C3																																																																																									
I1	2	4	6																																																																																								
I2	4	6	8																																																																																								
I3	6	8	10																																																																																								
Score 2	4																																																																																										
F1	F2	F3																																																																																									
I1	2	4	6																																																																																								
I2	4	6	8																																																																																								
I3	6	8	10																																																																																								
Score 2	2																																																																																										
K1	K2	K3																																																																																									
I1	2	4	6																																																																																								
I2	4	6	8																																																																																								
I3	6	8	10																																																																																								
Score 2	4																																																																																										
Posisi Durasi I & Beban H	Durasi I & Beban H	Durasi I & Kekuatan J	Dasar Kestabilan																																																																																								
<table border="1"> <thead> <tr><th>I1</th><th>I2</th><th>I3</th></tr> </thead> <tbody> <tr><td>H1</td><td>2</td><td>4</td><td>6</td></tr> <tr><td>H2</td><td>4</td><td>6</td><td>8</td></tr> <tr><td>H3</td><td>6</td><td>8</td><td>10</td></tr> <tr><td>H4</td><td>8</td><td>10</td><td>12</td></tr> <tr><td>Score 3</td><td colspan="3">2</td></tr> </tbody> </table>	I1	I2	I3	H1	2	4	6	H2	4	6	8	H3	6	8	10	H4	8	10	12	Score 3	2			<table border="1"> <thead> <tr><th>I1</th><th>I2</th><th>I3</th></tr> </thead> <tbody> <tr><td>H1</td><td>2</td><td>4</td><td>6</td></tr> <tr><td>H2</td><td>4</td><td>6</td><td>8</td></tr> <tr><td>H3</td><td>6</td><td>8</td><td>10</td></tr> <tr><td>H4</td><td>8</td><td>10</td><td>12</td></tr> <tr><td>Score 3</td><td colspan="3">2</td></tr> </tbody> </table>	I1	I2	I3	H1	2	4	6	H2	4	6	8	H3	6	8	10	H4	8	10	12	Score 3	2			<table border="1"> <thead> <tr><th>I1</th><th>I2</th><th>I3</th></tr> </thead> <tbody> <tr><td>J1</td><td>2</td><td>4</td><td>6</td></tr> <tr><td>J2</td><td>4</td><td>6</td><td>8</td></tr> <tr><td>J3</td><td>6</td><td>8</td><td>10</td></tr> <tr><td>J4</td><td>8</td><td>10</td><td>12</td></tr> <tr><td>Score 3</td><td colspan="3">4</td></tr> </tbody> </table>	I1	I2	I3	J1	2	4	6	J2	4	6	8	J3	6	8	10	J4	8	10	12	Score 3	4			<table border="1"> <thead> <tr><th>L1</th><th>L2</th><th>L3</th></tr> </thead> <tbody> <tr><td>I</td><td>4</td><td>9</td></tr> <tr><td>Total Kestabilan</td><td colspan="2">1</td></tr> </tbody> </table>	L1	L2	L3	I	4	9	Total Kestabilan	1											
I1	I2	I3																																																																																									
H1	2	4	6																																																																																								
H2	4	6	8																																																																																								
H3	6	8	10																																																																																								
H4	8	10	12																																																																																								
Score 3	2																																																																																										
I1	I2	I3																																																																																									
H1	2	4	6																																																																																								
H2	4	6	8																																																																																								
H3	6	8	10																																																																																								
H4	8	10	12																																																																																								
Score 3	2																																																																																										
I1	I2	I3																																																																																									
J1	2	4	6																																																																																								
J2	4	6	8																																																																																								
J3	6	8	10																																																																																								
J4	8	10	12																																																																																								
Score 3	4																																																																																										
L1	L2	L3																																																																																									
I	4	9																																																																																									
Total Kestabilan	1																																																																																										
Posisi Statis E & Durasi I	Frekkuensi D & Beban H	Posisi pergantian tangan I & Kekuatan J	Proses Bekerja																																																																																								
<table border="1"> <thead> <tr><th>B1</th><th>B2</th></tr> </thead> <tbody> <tr><td>I1</td><td>2</td><td>4</td></tr> <tr><td>I2</td><td>4</td><td>6</td></tr> <tr><td>I3</td><td>6</td><td>8</td></tr> <tr><td>Score 4</td><td colspan="2">2</td></tr> </tbody> </table>	B1	B2	I1	2	4	I2	4	6	I3	6	8	Score 4	2		<table border="1"> <thead> <tr><th>D1</th><th>D2</th><th>D3</th></tr> </thead> <tbody> <tr><td>H1</td><td>2</td><td>4</td><td>6</td></tr> <tr><td>H2</td><td>4</td><td>6</td><td>8</td></tr> <tr><td>H3</td><td>6</td><td>8</td><td>10</td></tr> <tr><td>H4</td><td>8</td><td>10</td><td>12</td></tr> <tr><td>Score 4</td><td colspan="3">4</td></tr> </tbody> </table>	D1	D2	D3	H1	2	4	6	H2	4	6	8	H3	6	8	10	H4	8	10	12	Score 4	4			<table border="1"> <thead> <tr><th>E1</th><th>E2</th></tr> </thead> <tbody> <tr><td>J1</td><td>2</td><td>4</td></tr> <tr><td>J2</td><td>4</td><td>6</td></tr> <tr><td>J3</td><td>6</td><td>8</td></tr> <tr><td>J4</td><td>8</td><td>10</td></tr> <tr><td>Score 4</td><td colspan="2">4</td></tr> </tbody> </table>	E1	E2	J1	2	4	J2	4	6	J3	6	8	J4	8	10	Score 4	4		<table border="1"> <thead> <tr><th>M1</th><th>M2</th><th>M3</th></tr> </thead> <tbody> <tr><td>I</td><td>4</td><td>9</td></tr> <tr><td>Total Proses Bekerja</td><td colspan="2">4</td></tr> </tbody> </table>	M1	M2	M3	I	4	9	Total Proses Bekerja	4																										
B1	B2																																																																																										
I1	2	4																																																																																									
I2	4	6																																																																																									
I3	6	8																																																																																									
Score 4	2																																																																																										
D1	D2	D3																																																																																									
H1	2	4	6																																																																																								
H2	4	6	8																																																																																								
H3	6	8	10																																																																																								
H4	8	10	12																																																																																								
Score 4	4																																																																																										
E1	E2																																																																																										
J1	2	4																																																																																									
J2	4	6																																																																																									
J3	6	8																																																																																									
J4	8	10																																																																																									
Score 4	4																																																																																										
M1	M2	M3																																																																																									
I	4	9																																																																																									
Total Proses Bekerja	4																																																																																										
Posisi Statis E & Beban H	Frekkuensi E & durasi I	Posisi pergantian tangan I & durasi I	Getaran																																																																																								
<table border="1"> <thead> <tr><th>H3</th><th>H4</th><th>H5</th></tr> </thead> <tbody> <tr><td>H1</td><td>2</td><td>4</td><td>6</td></tr> <tr><td>H2</td><td>4</td><td>6</td><td>8</td></tr> <tr><td>H3</td><td>6</td><td>8</td><td>10</td></tr> <tr><td>H4</td><td>8</td><td>10</td><td>12</td></tr> <tr><td>Score 5</td><td colspan="3">2</td></tr> </tbody> </table>	H3	H4	H5	H1	2	4	6	H2	4	6	8	H3	6	8	10	H4	8	10	12	Score 5	2			<table border="1"> <thead> <tr><th>D1</th><th>D2</th><th>D3</th></tr> </thead> <tbody> <tr><td>I1</td><td>2</td><td>4</td><td>6</td></tr> <tr><td>I2</td><td>4</td><td>6</td><td>8</td></tr> <tr><td>I3</td><td>6</td><td>8</td><td>10</td></tr> <tr><td>Score 5</td><td colspan="3">4</td></tr> </tbody> </table>	D1	D2	D3	I1	2	4	6	I2	4	6	8	I3	6	8	10	Score 5	4			<table border="1"> <thead> <tr><th>E1</th><th>E2</th></tr> </thead> <tbody> <tr><td>I1</td><td>2</td><td>4</td></tr> <tr><td>I2</td><td>4</td><td>6</td></tr> <tr><td>I3</td><td>6</td><td>8</td></tr> <tr><td>Score 5</td><td colspan="2">2</td></tr> </tbody> </table>	E1	E2	I1	2	4	I2	4	6	I3	6	8	Score 5	2		<table border="1"> <thead> <tr><th>N1</th><th>N2</th><th>N3</th></tr> </thead> <tbody> <tr><td>I</td><td>4</td><td>9</td></tr> <tr><td>Total Getaran</td><td colspan="2">1</td></tr> </tbody> </table>	N1	N2	N3	I	4	9	Total Getaran	1																								
H3	H4	H5																																																																																									
H1	2	4	6																																																																																								
H2	4	6	8																																																																																								
H3	6	8	10																																																																																								
H4	8	10	12																																																																																								
Score 5	2																																																																																										
D1	D2	D3																																																																																									
I1	2	4	6																																																																																								
I2	4	6	8																																																																																								
I3	6	8	10																																																																																								
Score 5	4																																																																																										
E1	E2																																																																																										
I1	2	4																																																																																									
I2	4	6																																																																																									
I3	6	8																																																																																									
Score 5	2																																																																																										
N1	N2	N3																																																																																									
I	4	9																																																																																									
Total Getaran	1																																																																																										
Frekkuensi E & durasi I	Total skor bahu/lengan = total skor 1 sampai 5	Total skor pergantian tangan = total skor 1 sampai 5	Stress Kerja																																																																																								
<table border="1"> <thead> <tr><th>B3</th><th>B4</th><th>B5</th></tr> </thead> <tbody> <tr><td>I1</td><td>2</td><td>4</td><td>6</td></tr> <tr><td>I2</td><td>4</td><td>6</td><td>8</td></tr> <tr><td>I3</td><td>6</td><td>8</td><td>10</td></tr> <tr><td>Score 6</td><td colspan="3">2</td></tr> </tbody> </table>	B3	B4	B5	I1	2	4	6	I2	4	6	8	I3	6	8	10	Score 6	2			18	16	<table border="1"> <thead> <tr><th>O1</th><th>O2</th><th>O3</th><th>O4</th></tr> </thead> <tbody> <tr><td>I</td><td>4</td><td>9</td><td>16</td></tr> <tr><td>Total Stress kerja</td><td colspan="3">1</td></tr> </tbody> </table>	O1	O2	O3	O4	I	4	9	16	Total Stress kerja	1																																																											
B3	B4	B5																																																																																									
I1	2	4	6																																																																																								
I2	4	6	8																																																																																								
I3	6	8	10																																																																																								
Score 6	2																																																																																										
O1	O2	O3	O4																																																																																								
I	4	9	16																																																																																								
Total Stress kerja	1																																																																																										
Total skor punggung = total skor 1 sampai 4 atau total skor 1 sampai 3 ditambah 5&6																																																																																											
8																																																																																											

Gambar 9 Rekapitulasi Kuisisioner

Rekapitulasi kuisisioner pengamat dan rekapitulasi kuisisioner operator. Ditemukan bahwa pada bagian tubuh punggung mendapatkan skor 8, pada bagian tubuh bahu/lengan mendapatkan skor 18, pada bagian tubuh pergelangan tangan 16, pada bagian tubuh leher mendapatkan skor 6, pada dasar kestabilan beban kerja didapatkan skor 1, pada beban proses kerja mendapatkan nilai skor 4, pada beban proses getaran mendapatka nilai 1, dan pada stress beban kerja mendapatkan skor 1. Jika keseluruhan skor dijumlahkan maka mendapatkan skor 55. Setelah itu akan dihitung untuk mencari skor E.

$$E(\%) = \frac{X}{X_{max}} \times 100\% =$$

$$E(\%) = \frac{55}{176} \times 100\% = 33,95\%$$

Tabel 11 Kategori Skor QEC

QEC score (E)	Aksi
≤ 40%	Bisa Diterima
41-50%	Penyelidikan lebih lanjut
51-70%	Penyelidikan lebih lanjut dan dilakukan perbaikan segera
> 70%	Penyelidikan lebih lanjut dan dilakukan perbaikan sekarang juga

Pada tabel kategori diatas ditemukan bahwa pada proses pengecatan mendapatkan nilai 33,95%, nilai tersebut termasuk dalam kategori resiko rendah dan tidak perlu dilakukan perbaikan.

h. Rekapitulasi Skor QEC Awal

Tabel 12 Rekapitulasi Skor QEC Awal

No	Pekerjaan	Score QEC Awal	Keterangan
1	Mesin Bor	66,47%	Perlu dilakukan perbaikan
2	Potong Manual	65,34%	Perlu dilakukan perbaikan
3	Potong Otomatis	39,24%	Tidak dilakukan perbaikan
4	Mesin Bubut	30,24%	Tidak dilakukan perbaikan
5	Pengelasan	78,97%	Perlu dilakukan perbaikan
6	Perakitan	35,18%	Tidak dilakukan perbaikan
7	Pengecatan	37,18%	Tidak dilakukan perbaikan

Pada rekapitulasi Skor QEC awal yang ada pada tabel diatas maka ada bisa didapatkan hasil bahwa skor <40% tidak perlu dilakukan perbaikan lagi dan skor >40% perlu dilakukan perbaikan secara lebih lanjut. Untuk perhitungan selanjutnya yang akan dihitung hanya pada stasiun kerja yang memang diperlukan perbaikan.

2. Perhitungan REBA Awal

a. Operator Mesin Bor



Gambar 10 Postur Kerja Operator Mesin Bor

Seorang pekerja memiliki sikap kerja seperti gambar diatas, untuk skoring postur tubuh sebagai berikut. Dibawah ini merupakan skoring postur badan.

Tabel 13 Skor Postur Tubuh

Postur tubuh	Skor	Keterangan	Skor akhir
Leher (neck)	2	25° kedepan	2
Batang tubuh (trunk)	3	45° kedepan	3
Kaki (legs)	2	Postur Kaki tidak seimbang dan menekuk membentuk 60° kedepan	3

Tabel diatas merupakan tabel skor untuk masing-masing postur tubuh para pekerja.

Tabel 14 Rekapitulasi Skor REBA

Tabel A	neck												
	1				2				3				
Legs													
	1	2	3	4	1	2	3	4	1	2	3	4	
Trunk	1	1	2	3	4	1	2	3	4	3	4	5	6
	2	2	3	4	5	3	4	5	6	4	5	6	7
	3	2	4	5	6	4	5	6	7	5	6	7	8

Usulan Perbaikan Fasilitas Kerja pada Produksi Parutan Kelapa Berdasarkan...

	4	3	5	6	7	5	6	7	8	6	7	8	9
	5	4	6	7	8	6	7	8	9	7	8	9	9

Pada perhitungan rekapitulasi skor postur badan tabel A diatas mendapatkan skor 6

Tabel 15 Skor Postur Tubuh

Postur tubuh	Skor	Keterangan	Skor akhir
Lengan Atas (Upper Arm)	3	75° kedepan dan +1 bahu dinaikkan	4
Lengan Bawah (Lower Arm)	2	130° kedepan	2
Pergelangan Tangan (Wrist)	2	20° keatas dan +1 karena berputar	3

Tabel diatas merupakan tabel skor untuk masing-masing postur tubuh para pekerja.

Tabel 16 Rekapitulasi Skor REBA

Tabel B	Lower Arm						
		1			2		
	Wrist	1	2	3	1	2	3
Upper Arm Skor	1	1	2	2	1	2	3
	2	1	2	3	2	3	4
	3	3	4	5	4	5	5
	4	4	5	5	5	6	7
	5	6	7	8	7	8	8
	6	7	8	8	8	9	9

Pada perhitungan rekapitulasi skor postur badan tabel B diatas mendapatkan skor 7

Tabel 17 Rekapitulasi Skor REBA

Skor A	Tabel C											
	Skor B											
	1	2	3	4	5	6	7	8	9	10	11	12
1	1	1	1	2	3	3	4	5	6	7	7	7
2	1	2	2	3	4	4	5	6	6	7	7	8
3	2	3	3	3	4	5	6	7	7	8	8	8
4	3	4	4	4	5	6	7	8	8	9	9	9
5	4	4	4	5	6	7	8	8	9	9	9	9
6	6	6	6	7	8	8	9	9	10	10	10	10
7	7	7	7	8	9	9	9	10	10	11	11	11
8	8	8	8	9	10	10	10	10	10	11	11	11

Pada tabel diatas didapatkan nilai skor REBA 9 yang didapatkan dari hasil rekapitulasi tabel B yang mendapatkan nilai skor 7 terhadap nilai rekapitulasi tabel A yang mendapatkan nilai skor 6. Dibawah ini merupakan tabel pengkategorian untuk skor REBA.

Tabel 18 Kategori Skor REBA

level aksi	Skor REBA	Level Resiko	Tindakan perbaikan
0	1	Bisa Diabaikan	Tidak Perlu
1	2-3	Rendah	Mungkin Perlu
2	4-7	Sedang	Perlu
3	8-10	Tinggi	Perlu segera
4	11+	Sangat Tinggi	Perlu saat ini juga

Dari perhitungan skor diatas tadi ditemukan nilai 9, yaitu jika dimasukkan pada tabel kategori masuk kedalam kategori resiko tinggi dan perlu dilakukan perbaikan segera.

b. Operator Pemotong Manual

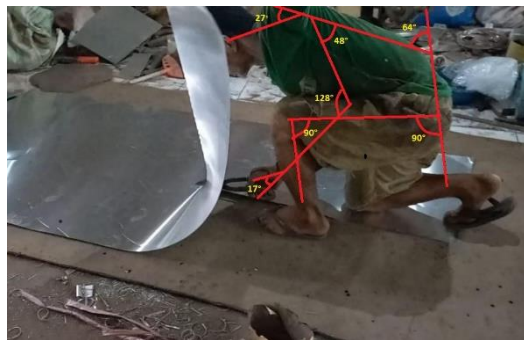

Gambar 11 Postur Kerja Operator Potong Manual

Seorang pekerja memiliki sikap kerja seperti gambar diatas, untuk skoring postur tubuh sebagai berikut.

Tabel 19 Skor Postur Tubuh

Postur tubuh	Skor	Keterangan	Skor akhir
Leher (neck)	2	27° kedepan dan +1 miring ke samping	3
Batang tubuh (trunk)	4	64° kedepan	4
Kaki (legs)	2	Postur Kaki tidak seimbang dan menekuk membentuk 90° kedepan	4

Tabel diatas merupakan tabel skor untuk masing-masing postur tubuh para pekerja.

Tabel 20 Rekapitulasi Skor REBA

Tabel A	neck	1				2				3			
	Legs												
		1	2	3	4	1	2	3	4	1	2	3	4
Trunk	1	1	2	3	4	1	2	3	4	3	4	5	6
	2	2	3	4	5	3	4	5	6	4	5	6	7
	3	2	4	5	6	4	5	6	7	5	6	7	8
	4	3	5	6	7	5	6	7	8	6	7	8	9
	5	4	6	7	8	6	7	8	9	7	8	9	9

Pada perhitungan rekapitulasi skor postur badan tabel A mendapatkan skor 9

Tabel 21 Skor Postur Tubuh

Postur tubuh	Skor	Keterangan	Skor akhir
Lengan Atas (Upper Arm)	3	48° kedepan dan +1 bahu dinaikkan	4
Lengan Bawah (Lower Arm)	2	128° kedepan	2
Pergelangan Tangan (Wrist)	2	17° keatas dan +1 karena berputar	3

Tabel diatas merupakan tabel skor untuk masing-masing postur tubuh para pekerja.

Tabel 22 Rekapitulasi Skor REBA

Tabel B	Lower Arm	1			2		
	Wrist	1	2	3	1	2	3
Upper Arm Skor	1	1	2	2	1	2	3
	2	1	2	3	2	3	4
	3	3	4	5	4	5	5

Usulan Perbaikan Fasilitas Kerja pada Produksi Parutan Kelapa Berdasarkan...

	4	4	5	5	5	6	7
	5	6	7	8	7	8	8
	6	7	8	8	8	9	9

Pada perhitungan rekapitulasi skor postur badan tabel A diatas mendapatkan skor 7.

Tabel 23 Rekapitulasi Skor REBA

Skor A	Tabel C											
	Skor B											
	1	2	3	4	5	6	7	8	9	10	11	12
1	1	1	1	2	3	3	4	5	6	7	7	7
2	1	2	2	3	4	4	5	6	6	7	7	8
3	2	3	3	3	4	5	6	7	7	8	8	8
4	3	4	4	4	5	6	7	8	8	9	9	9
5	4	4	4	5	6	7	8	8	9	9	9	9
6	6	6	6	7	8	8	9	9	10	10	10	10
7	7	7	7	8	9	9	9	10	10	11	11	11
8	8	8	8	9	10	10	10	10	10	11	11	11
9	9	9	9	10	10	10	11	11	11	12	12	12
10	10	10	10	11	11	11	11	12	12	12	12	12
11	11	11	11	11	12	12	12	12	12	12	12	12
12	12	12	12	12	12	12	12	12	12	12	12	12

Pada tabel diatas didapatkan nilai skor REBA 11 yang didapatkan dari hasil rekapitulasi tabel B yang mendapatkan nilai skor 7 terhadap nilai rekapitulasi tabel A yang mendapatkan nilai skor 9. Dibawah ini merupakan tabel pengkategorian untuk skor REBA.

Tabel 24 Kategori Skor REBA

level aksi	Skor REBA	Level Resiko	Tindakan perbaikan
0	1	Bisa Diabaikan	Tidak Perlu
1	2-3	Rendah	Mungkin Perlu
2	4-7	Sedang	Perlu
3	8-10	Tinggi	Perlu segera
4	11+	Sangat Tinggi	Perlu saat ini juga

Dari perhitungan skor diatas tadi ditemukan nilai 11, yaitu jika dimasukkan pada tabel kategori masuk kedalam kategori resiko sangat tinggi dan perlu dilakukan perbaikan saat ini juga.

3. Antropometri

Tabel 25 Antropometri Pekerja

Nama Perkerja/Operator	Kursi Kerja				Meja Kerja		
	TPO (cm)	LB (cm)	PP (cm)	TP (cm)	JT (cm)	TSD (cm)	TSB (cm)
Heru (Mesin Bor)	43	42	49	55	63	54	80
Minto (Potong manual)	42	44	50	56	65	57	85
Supriyanto (Pengelasan)	41	48	52	56	68	56	84
\bar{x} (x rata-rata)	42	45	50	56	65	56	83
σ (standar deviasi)	1.00	3.06	1.53	0.58	2.52	1.53	2.65

Diatas merupakan tabel antropometri dari para pekerja yang perlu dilakukan perbaikan.

4. Percentil

Dilakukan perhitungan percentil untuk menentukan ukuran meja kerja yang nantinya akan dibuat. Dalam perhitungan ini pada bagian yang nantinya dibutuhkan secara statis akan menggunakan percentile 99% dan pada bagian yang dibutuhkan secara dinamis akan menggunakan percentile 1-99%.

Hasil dari perhitungannya adalah sebagai berikut :

- a. TPO = 39 cm - 45 cm (dinamis)
- b. LB = 51 cm (statis)
- c. PP = 56 cm (statis)
- d. TP = 62 cm (statis)
- e. JT = 71 cm (statis)
- f. TSD = 52 cm - 60 cm (dinamis)
- g. TSB = 76 cm - 89 cm (dinamis)

5. Desain Gambar

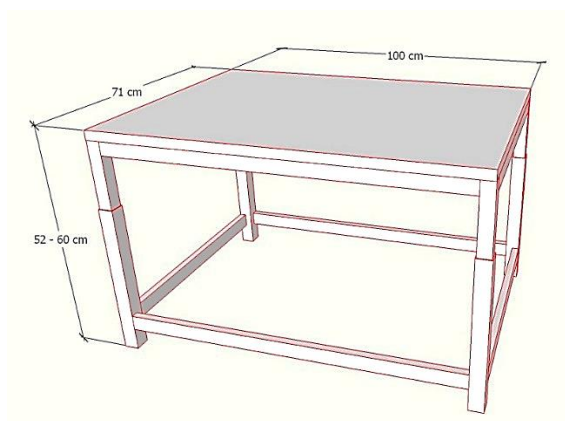

Gambar 12 Design Meja Kerja Mesin Bor

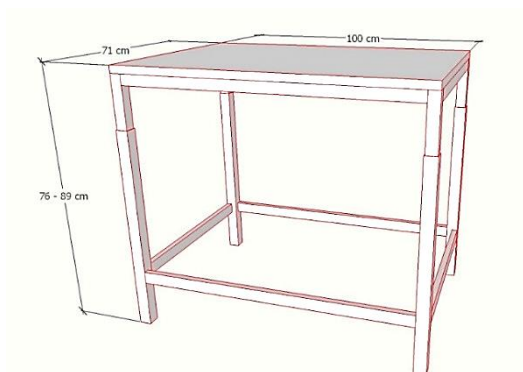

Gambar 13 Design Meja Kerja Pemotongan Manual

6. Kuisiонер QEC Akhir

Tabel 26 Rekapitulasi Kuisiонер Pengamat

Stasiun kerja	Punggung		Lengan/bahu		Pergelangan Tangan		leher
	1	2	1	2	1	2	
Mesin bor	A1	B4	C1	D3	E1	F2	G1
pemotong manual	A1	B4	C1	D3	E1	F1	G1
Pengelasan	A1	B4	C1	D3	E1	F2	G2

Pada tabel diatas merupakan rekapituasi dari jawaban dari kuisiонер pengamat.

Usulan Perbaikan Fasilitas Kerja pada Produksi Parutan Kelapa Berdasarkan...

Tabel 27 Rekapitulasi Kuisioner Operator

Stasiun kerja	Pertanyaan							
	H	I	J	K	L	M	N	O
Mesin bor	H1	I1	J2	K2	L1	M2	N3	O1
Pemotong manual	H1	I1	J2	K2	L1	M2	N1	O1
Pengelasan	H1	I2	J2	K2	L2	M2	N1	O1

Pada tabel diatas merupakan rekapituasi dari jawaban dari kuisioner operator.

a. Operator Mesin Bor

EXPOSURE SCORE	NAMA PEKERJA: Heru	TANGGAL	PEKERJAAN :Mesin Bor																																																																																								
Punggng	Bahu/Lengan	Pergelangan tangan	leher																																																																																								
Posisi Punggng A & Beban H	Tinggi C & Beban H	Gerakan Berulang F & Kekuatan J	Posisi Leher G & Durasi I																																																																																								
<table border="1" style="width: 100%; border-collapse: collapse;"> <tr><th>A1</th><th>A2</th><th>A3</th></tr> <tr><td>H1</td><td>2</td><td>4</td><td>6</td></tr> <tr><td>H2</td><td>4</td><td>6</td><td>8</td></tr> <tr><td>H3</td><td>6</td><td>8</td><td>10</td></tr> <tr><td>H4</td><td>8</td><td>10</td><td>12</td></tr> <tr><td>Score 1</td><td colspan="3">2</td></tr> </table>	A1	A2	A3	H1	2	4	6	H2	4	6	8	H3	6	8	10	H4	8	10	12	Score 1	2			<table border="1" style="width: 100%; border-collapse: collapse;"> <tr><th>C1</th><th>C2</th><th>C3</th></tr> <tr><td>H1</td><td>2</td><td>4</td><td>6</td></tr> <tr><td>H2</td><td>4</td><td>6</td><td>8</td></tr> <tr><td>H3</td><td>6</td><td>8</td><td>10</td></tr> <tr><td>H4</td><td>8</td><td>10</td><td>12</td></tr> <tr><td>Score 1</td><td colspan="3">2</td></tr> </table>	C1	C2	C3	H1	2	4	6	H2	4	6	8	H3	6	8	10	H4	8	10	12	Score 1	2			<table border="1" style="width: 100%; border-collapse: collapse;"> <tr><th>F1</th><th>F2</th><th>F3</th></tr> <tr><td>J1</td><td>2</td><td>4</td><td>6</td></tr> <tr><td>J2</td><td>4</td><td>6</td><td>8</td></tr> <tr><td>J3</td><td>6</td><td>8</td><td>10</td></tr> <tr><td>J4</td><td>8</td><td>10</td><td>12</td></tr> <tr><td>Score 1</td><td colspan="3">6</td></tr> </table>	F1	F2	F3	J1	2	4	6	J2	4	6	8	J3	6	8	10	J4	8	10	12	Score 1	6			<table border="1" style="width: 100%; border-collapse: collapse;"> <tr><th>G1</th><th>G2</th><th>G3</th></tr> <tr><td>I1</td><td>2</td><td>4</td><td>6</td></tr> <tr><td>I2</td><td>4</td><td>6</td><td>8</td></tr> <tr><td>I3</td><td>6</td><td>8</td><td>10</td></tr> <tr><td>Score 1</td><td colspan="3">2</td></tr> </table>	G1	G2	G3	I1	2	4	6	I2	4	6	8	I3	6	8	10	Score 1	2		
A1	A2	A3																																																																																									
H1	2	4	6																																																																																								
H2	4	6	8																																																																																								
H3	6	8	10																																																																																								
H4	8	10	12																																																																																								
Score 1	2																																																																																										
C1	C2	C3																																																																																									
H1	2	4	6																																																																																								
H2	4	6	8																																																																																								
H3	6	8	10																																																																																								
H4	8	10	12																																																																																								
Score 1	2																																																																																										
F1	F2	F3																																																																																									
J1	2	4	6																																																																																								
J2	4	6	8																																																																																								
J3	6	8	10																																																																																								
J4	8	10	12																																																																																								
Score 1	6																																																																																										
G1	G2	G3																																																																																									
I1	2	4	6																																																																																								
I2	4	6	8																																																																																								
I3	6	8	10																																																																																								
Score 1	2																																																																																										
Posisi Punggng A & Durasi I	Tinggi C & Durasi I	Gerakan Berulang F & Durasi I	Kebutuhan Visual K & Durasi I																																																																																								
<table border="1" style="width: 100%; border-collapse: collapse;"> <tr><th>A1</th><th>A2</th><th>A3</th></tr> <tr><td>I1</td><td>2</td><td>4</td><td>6</td></tr> <tr><td>I2</td><td>4</td><td>6</td><td>8</td></tr> <tr><td>I3</td><td>6</td><td>8</td><td>10</td></tr> <tr><td>Score 2</td><td colspan="3">2</td></tr> </table>	A1	A2	A3	I1	2	4	6	I2	4	6	8	I3	6	8	10	Score 2	2			<table border="1" style="width: 100%; border-collapse: collapse;"> <tr><th>C1</th><th>C2</th><th>C3</th></tr> <tr><td>I1</td><td>2</td><td>4</td><td>6</td></tr> <tr><td>I2</td><td>4</td><td>6</td><td>8</td></tr> <tr><td>I3</td><td>6</td><td>8</td><td>10</td></tr> <tr><td>Score 2</td><td colspan="3">2</td></tr> </table>	C1	C2	C3	I1	2	4	6	I2	4	6	8	I3	6	8	10	Score 2	2			<table border="1" style="width: 100%; border-collapse: collapse;"> <tr><th>F1</th><th>F2</th><th>F3</th></tr> <tr><td>I1</td><td>2</td><td>4</td><td>6</td></tr> <tr><td>I2</td><td>4</td><td>6</td><td>8</td></tr> <tr><td>I3</td><td>6</td><td>8</td><td>10</td></tr> <tr><td>Score 2</td><td colspan="3">4</td></tr> </table>	F1	F2	F3	I1	2	4	6	I2	4	6	8	I3	6	8	10	Score 2	4			<table border="1" style="width: 100%; border-collapse: collapse;"> <tr><th>K1</th><th>K2</th><th>K3</th></tr> <tr><td>I1</td><td>2</td><td>4</td><td>6</td></tr> <tr><td>I2</td><td>4</td><td>6</td><td>8</td></tr> <tr><td>I3</td><td>6</td><td>8</td><td>10</td></tr> <tr><td>Score 2</td><td colspan="3">4</td></tr> </table>	K1	K2	K3	I1	2	4	6	I2	4	6	8	I3	6	8	10	Score 2	4														
A1	A2	A3																																																																																									
I1	2	4	6																																																																																								
I2	4	6	8																																																																																								
I3	6	8	10																																																																																								
Score 2	2																																																																																										
C1	C2	C3																																																																																									
I1	2	4	6																																																																																								
I2	4	6	8																																																																																								
I3	6	8	10																																																																																								
Score 2	2																																																																																										
F1	F2	F3																																																																																									
I1	2	4	6																																																																																								
I2	4	6	8																																																																																								
I3	6	8	10																																																																																								
Score 2	4																																																																																										
K1	K2	K3																																																																																									
I1	2	4	6																																																																																								
I2	4	6	8																																																																																								
I3	6	8	10																																																																																								
Score 2	4																																																																																										
Posisi Durasi I & Beban H	Durasi I & Beban H	Durasi I & Kekuatan J	Dasar Kestabilan																																																																																								
<table border="1" style="width: 100%; border-collapse: collapse;"> <tr><th>I1</th><th>I2</th><th>I3</th></tr> <tr><td>H1</td><td>2</td><td>4</td><td>6</td></tr> <tr><td>H2</td><td>4</td><td>6</td><td>8</td></tr> <tr><td>H3</td><td>6</td><td>8</td><td>10</td></tr> <tr><td>H4</td><td>8</td><td>10</td><td>12</td></tr> <tr><td>Score 3</td><td colspan="3">2</td></tr> </table>	I1	I2	I3	H1	2	4	6	H2	4	6	8	H3	6	8	10	H4	8	10	12	Score 3	2			<table border="1" style="width: 100%; border-collapse: collapse;"> <tr><th>I1</th><th>I2</th><th>I3</th></tr> <tr><td>H1</td><td>2</td><td>4</td><td>6</td></tr> <tr><td>H2</td><td>4</td><td>6</td><td>8</td></tr> <tr><td>H3</td><td>6</td><td>8</td><td>10</td></tr> <tr><td>H4</td><td>8</td><td>10</td><td>12</td></tr> <tr><td>Score 3</td><td colspan="3">2</td></tr> </table>	I1	I2	I3	H1	2	4	6	H2	4	6	8	H3	6	8	10	H4	8	10	12	Score 3	2			<table border="1" style="width: 100%; border-collapse: collapse;"> <tr><th>J1</th><th>J2</th><th>J3</th></tr> <tr><td>I1</td><td>2</td><td>4</td><td>6</td></tr> <tr><td>I2</td><td>4</td><td>6</td><td>8</td></tr> <tr><td>I3</td><td>6</td><td>8</td><td>10</td></tr> <tr><td>I4</td><td>8</td><td>10</td><td>12</td></tr> <tr><td>Score 3</td><td colspan="3">4</td></tr> </table>	J1	J2	J3	I1	2	4	6	I2	4	6	8	I3	6	8	10	I4	8	10	12	Score 3	4			<table border="1" style="width: 100%; border-collapse: collapse;"> <tr><th>L1</th><th>L2</th><th>L3</th></tr> <tr><td>I1</td><td>2</td><td>4</td><td>6</td></tr> <tr><td>I2</td><td>4</td><td>6</td><td>8</td></tr> <tr><td>I3</td><td>6</td><td>8</td><td>10</td></tr> <tr><td>Total Kestabilan</td><td colspan="3">1</td></tr> </table>	L1	L2	L3	I1	2	4	6	I2	4	6	8	I3	6	8	10	Total Kestabilan	1		
I1	I2	I3																																																																																									
H1	2	4	6																																																																																								
H2	4	6	8																																																																																								
H3	6	8	10																																																																																								
H4	8	10	12																																																																																								
Score 3	2																																																																																										
I1	I2	I3																																																																																									
H1	2	4	6																																																																																								
H2	4	6	8																																																																																								
H3	6	8	10																																																																																								
H4	8	10	12																																																																																								
Score 3	2																																																																																										
J1	J2	J3																																																																																									
I1	2	4	6																																																																																								
I2	4	6	8																																																																																								
I3	6	8	10																																																																																								
I4	8	10	12																																																																																								
Score 3	4																																																																																										
L1	L2	L3																																																																																									
I1	2	4	6																																																																																								
I2	4	6	8																																																																																								
I3	6	8	10																																																																																								
Total Kestabilan	1																																																																																										
Posisi Statis E & Durasi I	Frekuensi D & Beban H	Posisi pergelangan tangan E & Kekuatan J	Proses Bekerja																																																																																								
<table border="1" style="width: 100%; border-collapse: collapse;"> <tr><th>B1</th><th>B2</th></tr> <tr><td>I1</td><td>2</td><td>4</td></tr> <tr><td>I2</td><td>4</td><td>6</td></tr> <tr><td>I3</td><td>6</td><td>8</td></tr> <tr><td>Score 4</td><td colspan="2">4</td></tr> </table>	B1	B2	I1	2	4	I2	4	6	I3	6	8	Score 4	4		<table border="1" style="width: 100%; border-collapse: collapse;"> <tr><th>D1</th><th>D2</th><th>D3</th></tr> <tr><td>H1</td><td>2</td><td>4</td><td>6</td></tr> <tr><td>H2</td><td>4</td><td>6</td><td>8</td></tr> <tr><td>H3</td><td>6</td><td>8</td><td>10</td></tr> <tr><td>H4</td><td>8</td><td>10</td><td>12</td></tr> <tr><td>Score 4</td><td colspan="3">6</td></tr> </table>	D1	D2	D3	H1	2	4	6	H2	4	6	8	H3	6	8	10	H4	8	10	12	Score 4	6			<table border="1" style="width: 100%; border-collapse: collapse;"> <tr><th>E1</th><th>E2</th></tr> <tr><td>J1</td><td>2</td><td>4</td></tr> <tr><td>J2</td><td>4</td><td>6</td></tr> <tr><td>J3</td><td>6</td><td>8</td></tr> <tr><td>J4</td><td>8</td><td>10</td></tr> <tr><td>Score 4</td><td colspan="2">4</td></tr> </table>	E1	E2	J1	2	4	J2	4	6	J3	6	8	J4	8	10	Score 4	4		<table border="1" style="width: 100%; border-collapse: collapse;"> <tr><th>M1</th><th>M2</th><th>M3</th></tr> <tr><td>I1</td><td>2</td><td>4</td><td>6</td></tr> <tr><td>Total Proses Bekerja</td><td colspan="3">4</td></tr> </table>	M1	M2	M3	I1	2	4	6	Total Proses Bekerja	4																									
B1	B2																																																																																										
I1	2	4																																																																																									
I2	4	6																																																																																									
I3	6	8																																																																																									
Score 4	4																																																																																										
D1	D2	D3																																																																																									
H1	2	4	6																																																																																								
H2	4	6	8																																																																																								
H3	6	8	10																																																																																								
H4	8	10	12																																																																																								
Score 4	6																																																																																										
E1	E2																																																																																										
J1	2	4																																																																																									
J2	4	6																																																																																									
J3	6	8																																																																																									
J4	8	10																																																																																									
Score 4	4																																																																																										
M1	M2	M3																																																																																									
I1	2	4	6																																																																																								
Total Proses Bekerja	4																																																																																										
Frekuensi E & Beban H	Frekuensi E & Durasi I	Posisi pergelangan tangan E & Durasi I	Proses Getaran																																																																																								
<table border="1" style="width: 100%; border-collapse: collapse;"> <tr><th>B3</th><th>B4</th><th>B5</th></tr> <tr><td>H1</td><td>2</td><td>4</td><td>6</td></tr> <tr><td>H2</td><td>4</td><td>6</td><td>8</td></tr> <tr><td>H3</td><td>6</td><td>8</td><td>10</td></tr> <tr><td>H4</td><td>8</td><td>10</td><td>12</td></tr> <tr><td>Score 5</td><td colspan="3">4</td></tr> </table>	B3	B4	B5	H1	2	4	6	H2	4	6	8	H3	6	8	10	H4	8	10	12	Score 5	4			<table border="1" style="width: 100%; border-collapse: collapse;"> <tr><th>D1</th><th>D2</th><th>D3</th></tr> <tr><td>I1</td><td>2</td><td>4</td><td>6</td></tr> <tr><td>I2</td><td>4</td><td>6</td><td>8</td></tr> <tr><td>I3</td><td>6</td><td>8</td><td>10</td></tr> <tr><td>Score 5</td><td colspan="3">6</td></tr> </table>	D1	D2	D3	I1	2	4	6	I2	4	6	8	I3	6	8	10	Score 5	6			<table border="1" style="width: 100%; border-collapse: collapse;"> <tr><th>E1</th><th>E2</th></tr> <tr><td>I1</td><td>2</td><td>4</td></tr> <tr><td>I2</td><td>4</td><td>6</td></tr> <tr><td>I3</td><td>6</td><td>8</td></tr> <tr><td>Score 5</td><td colspan="2">2</td></tr> </table>	E1	E2	I1	2	4	I2	4	6	I3	6	8	Score 5	2		<table border="1" style="width: 100%; border-collapse: collapse;"> <tr><th>N1</th><th>N2</th><th>N3</th></tr> <tr><td>I1</td><td>2</td><td>4</td><td>6</td></tr> <tr><td>Total Getaran</td><td colspan="3">9</td></tr> </table>	N1	N2	N3	I1	2	4	6	Total Getaran	9																							
B3	B4	B5																																																																																									
H1	2	4	6																																																																																								
H2	4	6	8																																																																																								
H3	6	8	10																																																																																								
H4	8	10	12																																																																																								
Score 5	4																																																																																										
D1	D2	D3																																																																																									
I1	2	4	6																																																																																								
I2	4	6	8																																																																																								
I3	6	8	10																																																																																								
Score 5	6																																																																																										
E1	E2																																																																																										
I1	2	4																																																																																									
I2	4	6																																																																																									
I3	6	8																																																																																									
Score 5	2																																																																																										
N1	N2	N3																																																																																									
I1	2	4	6																																																																																								
Total Getaran	9																																																																																										
Frekuensi E & Durasi I	Total skor bahu/lengan = total skor 1 sampai 5	Total skor pergelangan tangan = total skor 1 sampai 5	Stress Kerja Akibat Keluhan																																																																																								
<table border="1" style="width: 100%; border-collapse: collapse;"> <tr><th>B3</th><th>B4</th><th>B5</th></tr> <tr><td>I1</td><td>2</td><td>4</td><td>6</td></tr> <tr><td>I2</td><td>4</td><td>6</td><td>8</td></tr> <tr><td>I3</td><td>6</td><td>8</td><td>10</td></tr> <tr><td>Score 6</td><td colspan="3">4</td></tr> </table>	B3	B4	B5	I1	2	4	6	I2	4	6	8	I3	6	8	10	Score 6	4			18	20	<table border="1" style="width: 100%; border-collapse: collapse;"> <tr><th>O1</th><th>O2</th><th>O3</th><th>O4</th></tr> <tr><td>I1</td><td>2</td><td>4</td><td>6</td><td>8</td></tr> <tr><td>Total stress kerja</td><td colspan="4">1</td></tr> </table>	O1	O2	O3	O4	I1	2	4	6	8	Total stress kerja	1																																																										
B3	B4	B5																																																																																									
I1	2	4	6																																																																																								
I2	4	6	8																																																																																								
I3	6	8	10																																																																																								
Score 6	4																																																																																										
O1	O2	O3	O4																																																																																								
I1	2	4	6	8																																																																																							
Total stress kerja	1																																																																																										
Total skor punggng = total skor 1 sampai 4 atau total skor 1 sampai 5 ditambah 5x6																																																																																											
14																																																																																											

Gambar 14 Rekapitulasi Kuisioner

Rekapitulasi kuisioner pengamat dan rekapitulasi kuisioner operator. Ditemukan bahwa pada bagian tubuh punggng mendapatkan skor 14, pada bagian tubuh bahu/lengan mendapatkan skor 18, pada bagian tubuh pergelangan tangan 20, pada bagian tubuh leher mendapatkan skor 6, pada dasar kestabilan beban kerja didapatkan skor 1, pada beban proses kerja mendapatkan nilai skor 4, pada beban proses getaran mendapatka nilai 9, dan pada stress beban kerja mendapatkan skor 1. Jika keseluruhan skor dijumlahkan maka mendapatkan skor 73. Setelah itu akan dihitung untuk mencari skor E.

$$E(\%) = \frac{X}{X_{max}} \times 100\% =$$

$$E(\%) = \frac{73}{176} \times 100\% = 41,14\%$$

Tabel 28 Kategori Skor QEC

QEC score (E)	Aksi
≤ 40%	Bisa Diterima
41-50%	Penyelidikan lebih lanjut
51-70%	Penyelidikan lebih lanjut dan dilakukan perbaikan segera
> 70%	Penyelidikan lebih lanjut dan dilakukan perbaikan sekarang juga

Pada tabel kategori diatas ditemukan bahwa pada proses mesin bor mendapatkan nilai 41,14% nilai tersebut termasuk dalam kategori resiko menengah dan suatu saat bisa dilakukan penelitian.

b. Operator Pemotongan Manual

EXPOSURE SCORE	NAMA PEKERJA: Minto	TANGGAL :	PEKERJAAN :Potong Manual
Punggung Posisi Dukung A & Eban H H1 2 4 6 H2 4 6 8 H3 6 8 10 H4 8 10 12 Score 1 2	Bahu/Lengan Tinggi C & Eban H C1 C2 C3 H1 2 4 6 H2 4 6 8 H3 6 8 10 H4 8 10 12 Score 1 2 Tinggi C & Durasi I C1 C2 C3 H1 2 4 6 H2 4 6 8 H3 6 8 10 Score 2 2 Durasi I & Eban H H1 12 13 H2 4 6 8 H3 6 8 10 H4 8 10 12 Score 3 2 Frekuensi D & Eban H D1 D2 D3 H1 2 4 6 H2 4 6 8 H3 6 8 10 H4 8 10 12 Score 4 6 Frekuensi B & durasi I D1 D2 D3 H1 2 4 6 H2 4 6 8 H3 6 8 10 H4 8 10 12 Score 5 6 Total skor bahu/lengan = total skor 1 sampai 5 18	Pergelangan tangan Gerakan Berulang F & Kekuatan J F1 F2 F3 J1 2 4 6 J2 4 6 8 J3 6 8 10 J4 8 10 12 Score 1 4 Gerakan Berulang F & Durasi I F1 F2 F3 I1 2 4 6 I2 4 6 8 I3 6 8 10 Score 2 2 Durasi I & Kekuatan J I1 I2 I3 J1 2 4 6 J2 4 6 8 J3 6 8 10 J4 8 10 12 Score 3 4 Posisi pergelangan tangan E & Kekuatan J E1 E2 J1 2 4 J2 4 6 J3 6 8 J4 8 10 Score 4 4 Posisi pergelangan tangan E & Durasi I E1 E2 I1 2 4 I2 4 6 I3 6 8 Score 5 2 Total skor pergelangan tangan = total skor 1 sampai 5 16	Leher Posisi Leher G & Durasi I G1 G2 G3 I1 2 4 6 I2 4 6 8 I3 6 8 10 Score 1 2 Kebutuhan Visual K & Durasi I K1 K2 K3 I1 2 4 6 I2 4 6 8 I3 6 8 10 Score 2 2 Total skor pergelangan tangan = total skor 1 sampai 2 6 Dasar Kestabilan L1 L2 L3 L 4 9 Total Kestabilan 1 Proses Bekerja M1 M2 M3 L 4 9 Total Proses Bekerja 4 Getaran N1 N2 N3 L 4 9 Total Getaran 1 Stress Kerja O1 O2 O3 O4 L 4 9 16 Total Stress kerja 1
Untuk pekerjaan statis gunakan skor 4 Untuk material handling gunakan skor 5 dan 6 Posisi Statis B & Durasi I B1 B2 I1 2 4 I2 4 6 I3 6 8 Score 4 4 Frekuensi B & Eban H B3 B4 B5 H1 2 4 6 H2 4 6 8 H3 6 8 10 H4 8 10 12 Score 5 4 Frekuensi B & durasi I B3 B4 B5 I1 2 4 6 I2 4 6 8 I3 6 8 10 Score 6 4 Total skor punggung = total skor 1 sampai 4 atau total skor 1 sampai 3 ditambah 5&6 14			

Gambar 15 Rekapitulasi Kuisioner

Rekapitulasi kuisioner pengamat dan rekapitulasi kuisioner operator. Ditemukan bahwa pada bagian tubuh punggung mendapatkan skor 14, pada bagian tubuh bahu/lengan mendapatkan skor 18, pada bagian tubuh pergelangan tangan 16, pada bagian tubuh leher mendapatkan skor 6, pada dasar kestabilan beban kerja didapatkan skor 1, pada beban proses kerja mendapatkan nilai skor 4, pada beban proses getaran mendapatka nilai 1, dan pada stress beban kerja mendapatkan skor 1. Jika keseluruhan skor dijumlahkan maka mendapatkan skor 61. Setelah itu akan dihitung untuk mencari skor E.

$$E(\%) \frac{X}{X_{max}} \times 100\% =$$

$$E(\%) \frac{61}{176} \times 100\% = 34,65\%$$

Tabel 29 Kategori Skor QEC

QEC score (E)	Aksi
≤ 40%	Bisa Diterima
41-50%	Penyelidikan lebih lanjut
51-70%	Penyelidikan lebih lanjut dan dilakukan perbaikan segera
> 70%	Penyelidikan lebih lanjut dan dilakukan perbaikan sekarang juga

Pada tabel kategori diatas ditemukan bahwa pada proses pemotongan manual mendapatkan nilai 34,65%, nilai tersebut termasuk dalam kategori resiko rendah dan tidak perlu perbaikan.

c. Operator Pengelasan

Usulan Perbaikan Fasilitas Kerja pada Produksi Parutan Kelapa Berdasarkan...

EXPOSURE SCORE	NAMA PEKERJA: Supriyanto	TANGGAL :	PEKERJAAN : Pengelasan																																																																																																																																																																																																																																																																																																																																																																																																																									
Punggung Posisi Punggung A & Beban H <table border="1" style="width: 100%; border-collapse: collapse;"> <tr><th>A1</th><th>A2</th><th>A3</th></tr> <tr><td>H1</td><td>2</td><td>4</td><td>6</td></tr> <tr><td>H2</td><td>4</td><td>6</td><td>8</td></tr> <tr><td>H3</td><td>6</td><td>8</td><td>10</td></tr> <tr><td>H4</td><td>8</td><td>10</td><td>12</td></tr> <tr><td>Score 1</td><td colspan="3">2</td></tr> </table> Posisi Punggung A & Durasi I <table border="1" style="width: 100%; border-collapse: collapse;"> <tr><th>A1</th><th>A2</th><th>A3</th></tr> <tr><td>I1</td><td>2</td><td>4</td><td>6</td></tr> <tr><td>I2</td><td>4</td><td>6</td><td>8</td></tr> <tr><td>I3</td><td>6</td><td>8</td><td>10</td></tr> <tr><td>Score 2</td><td colspan="3">4</td></tr> </table> Posisi Durasi I & Beban H <table border="1" style="width: 100%; border-collapse: collapse;"> <tr><th>I1</th><th>I2</th><th>I3</th></tr> <tr><td>H1</td><td>2</td><td>4</td><td>6</td></tr> <tr><td>H2</td><td>4</td><td>6</td><td>8</td></tr> <tr><td>H3</td><td>6</td><td>8</td><td>10</td></tr> <tr><td>H4</td><td>8</td><td>10</td><td>12</td></tr> <tr><td>Score 3</td><td colspan="3">4</td></tr> </table> <p>Untuk pekerjaan statis gunakan skoring 4 Untuk material handling gunakan skoring 5 dan 6</p> Posisi Statis B & Durasi I <table border="1" style="width: 100%; border-collapse: collapse;"> <tr><th>B1</th><th>B2</th></tr> <tr><td>J1</td><td>2</td><td>4</td></tr> <tr><td>J2</td><td>4</td><td>6</td></tr> <tr><td>J3</td><td>6</td><td>8</td></tr> <tr><td>Score 4</td><td colspan="2">6</td></tr> </table> Frekuensi B & Beban H <table border="1" style="width: 100%; border-collapse: collapse;"> <tr><th>B3</th><th>B4</th><th>B5</th></tr> <tr><td>H1</td><td>2</td><td>4</td><td>6</td></tr> <tr><td>H2</td><td>4</td><td>6</td><td>8</td></tr> <tr><td>H3</td><td>6</td><td>8</td><td>10</td></tr> <tr><td>H4</td><td>8</td><td>10</td><td>12</td></tr> <tr><td>Score 5</td><td colspan="3">4</td></tr> </table> Frekuensi B & durasi I <table border="1" style="width: 100%; border-collapse: collapse;"> <tr><th>B3</th><th>B4</th><th>B5</th></tr> <tr><td>I1</td><td>2</td><td>4</td><td>6</td></tr> <tr><td>I2</td><td>4</td><td>6</td><td>8</td></tr> <tr><td>I3</td><td>6</td><td>8</td><td>10</td></tr> <tr><td>Score 6</td><td colspan="3">6</td></tr> </table> <p>Total skor punggung = total skor 1 sampai 4 atau total skor 1 sampai 3 ditambah 5&6 20</p>	A1	A2	A3	H1	2	4	6	H2	4	6	8	H3	6	8	10	H4	8	10	12	Score 1	2			A1	A2	A3	I1	2	4	6	I2	4	6	8	I3	6	8	10	Score 2	4			I1	I2	I3	H1	2	4	6	H2	4	6	8	H3	6	8	10	H4	8	10	12	Score 3	4			B1	B2	J1	2	4	J2	4	6	J3	6	8	Score 4	6		B3	B4	B5	H1	2	4	6	H2	4	6	8	H3	6	8	10	H4	8	10	12	Score 5	4			B3	B4	B5	I1	2	4	6	I2	4	6	8	I3	6	8	10	Score 6	6			Bahu/Lengan Tinggi C & Beban H <table border="1" style="width: 100%; border-collapse: collapse;"> <tr><th>C1</th><th>C2</th><th>C3</th></tr> <tr><td>H1</td><td>2</td><td>4</td><td>6</td></tr> <tr><td>H2</td><td>4</td><td>6</td><td>8</td></tr> <tr><td>H3</td><td>6</td><td>8</td><td>10</td></tr> <tr><td>H4</td><td>8</td><td>10</td><td>12</td></tr> <tr><td>Score 1</td><td colspan="3">2</td></tr> </table> Tinggi C & Durasi I <table border="1" style="width: 100%; border-collapse: collapse;"> <tr><th>C1</th><th>C2</th><th>C3</th></tr> <tr><td>I1</td><td>2</td><td>4</td><td>6</td></tr> <tr><td>I2</td><td>4</td><td>6</td><td>8</td></tr> <tr><td>I3</td><td>6</td><td>8</td><td>10</td></tr> <tr><td>Score 2</td><td colspan="3">2</td></tr> </table> Durasi I & Beban H <table border="1" style="width: 100%; border-collapse: collapse;"> <tr><th>I1</th><th>I2</th><th>I3</th></tr> <tr><td>H1</td><td>2</td><td>4</td><td>6</td></tr> <tr><td>H2</td><td>4</td><td>6</td><td>8</td></tr> <tr><td>H3</td><td>6</td><td>8</td><td>10</td></tr> <tr><td>H4</td><td>8</td><td>10</td><td>12</td></tr> <tr><td>Score 3</td><td colspan="3">2</td></tr> </table> Frekuensi D & Beban H <table border="1" style="width: 100%; border-collapse: collapse;"> <tr><th>D1</th><th>D2</th><th>D3</th></tr> <tr><td>H1</td><td>2</td><td>4</td><td>6</td></tr> <tr><td>H2</td><td>4</td><td>6</td><td>8</td></tr> <tr><td>H3</td><td>6</td><td>8</td><td>10</td></tr> <tr><td>H4</td><td>8</td><td>10</td><td>12</td></tr> <tr><td>Score 4</td><td colspan="3">6</td></tr> </table> Frekuensi B & durasi I <table border="1" style="width: 100%; border-collapse: collapse;"> <tr><th>D1</th><th>D2</th><th>D3</th></tr> <tr><td>I1</td><td>2</td><td>4</td><td>6</td></tr> <tr><td>I2</td><td>4</td><td>6</td><td>8</td></tr> <tr><td>I3</td><td>6</td><td>8</td><td>10</td></tr> <tr><td>Score 5</td><td colspan="3">6</td></tr> </table> <p>Total skor bahu/lengan = total skor 1 sampai 5 18</p>	C1	C2	C3	H1	2	4	6	H2	4	6	8	H3	6	8	10	H4	8	10	12	Score 1	2			C1	C2	C3	I1	2	4	6	I2	4	6	8	I3	6	8	10	Score 2	2			I1	I2	I3	H1	2	4	6	H2	4	6	8	H3	6	8	10	H4	8	10	12	Score 3	2			D1	D2	D3	H1	2	4	6	H2	4	6	8	H3	6	8	10	H4	8	10	12	Score 4	6			D1	D2	D3	I1	2	4	6	I2	4	6	8	I3	6	8	10	Score 5	6			Pergelangan tangan Gerakan Berulang F & Kekuatan J <table border="1" style="width: 100%; border-collapse: collapse;"> <tr><th>F1</th><th>F2</th><th>F3</th></tr> <tr><td>J1</td><td>2</td><td>4</td><td>6</td></tr> <tr><td>J2</td><td>4</td><td>6</td><td>8</td></tr> <tr><td>J3</td><td>6</td><td>8</td><td>10</td></tr> <tr><td>J4</td><td>8</td><td>10</td><td>12</td></tr> <tr><td>Score 1</td><td colspan="3">6</td></tr> </table> Gerakan Berulang F & Durasi I <table border="1" style="width: 100%; border-collapse: collapse;"> <tr><th>F1</th><th>F2</th><th>F3</th></tr> <tr><td>I1</td><td>2</td><td>4</td><td>6</td></tr> <tr><td>I2</td><td>4</td><td>6</td><td>8</td></tr> <tr><td>I3</td><td>6</td><td>8</td><td>10</td></tr> <tr><td>Score 2</td><td colspan="3">4</td></tr> </table> Durasi I & Kekuatan J <table border="1" style="width: 100%; border-collapse: collapse;"> <tr><th>I1</th><th>I2</th><th>I3</th></tr> <tr><td>J1</td><td>2</td><td>4</td><td>6</td></tr> <tr><td>J2</td><td>4</td><td>6</td><td>8</td></tr> <tr><td>J3</td><td>6</td><td>8</td><td>10</td></tr> <tr><td>J4</td><td>8</td><td>10</td><td>12</td></tr> <tr><td>Score 3</td><td colspan="3">4</td></tr> </table> Posisi pergelangan tangan E & Kekuatan J <table border="1" style="width: 100%; border-collapse: collapse;"> <tr><th>E1</th><th>E2</th></tr> <tr><td>J1</td><td>2</td><td>4</td></tr> <tr><td>J2</td><td>4</td><td>6</td></tr> <tr><td>J3</td><td>6</td><td>8</td></tr> <tr><td>J4</td><td>8</td><td>10</td></tr> <tr><td>Score 4</td><td colspan="2">4</td></tr> </table> Posisi pergelangan tangan E & durasi I <table border="1" style="width: 100%; border-collapse: collapse;"> <tr><th>E1</th><th>E2</th></tr> <tr><td>I1</td><td>2</td><td>4</td></tr> <tr><td>I2</td><td>4</td><td>6</td></tr> <tr><td>I3</td><td>6</td><td>8</td></tr> <tr><td>Score 5</td><td colspan="2">2</td></tr> </table> <p>Total skor pergelangan tangan = total skor 1 sampai 5 18</p>	F1	F2	F3	J1	2	4	6	J2	4	6	8	J3	6	8	10	J4	8	10	12	Score 1	6			F1	F2	F3	I1	2	4	6	I2	4	6	8	I3	6	8	10	Score 2	4			I1	I2	I3	J1	2	4	6	J2	4	6	8	J3	6	8	10	J4	8	10	12	Score 3	4			E1	E2	J1	2	4	J2	4	6	J3	6	8	J4	8	10	Score 4	4		E1	E2	I1	2	4	I2	4	6	I3	6	8	Score 5	2		Leher Posisi Leher G & Durasi I <table border="1" style="width: 100%; border-collapse: collapse;"> <tr><th>G1</th><th>G2</th><th>G3</th></tr> <tr><td>I1</td><td>2</td><td>4</td><td>6</td></tr> <tr><td>I2</td><td>4</td><td>6</td><td>8</td></tr> <tr><td>I3</td><td>6</td><td>8</td><td>10</td></tr> <tr><td>Score 1</td><td colspan="3">4</td></tr> </table> Kebutuhan Visual K & Durasi I <table border="1" style="width: 100%; border-collapse: collapse;"> <tr><th>K1</th><th>K2</th><th>K3</th></tr> <tr><td>I1</td><td>2</td><td>4</td><td>6</td></tr> <tr><td>I2</td><td>4</td><td>6</td><td>8</td></tr> <tr><td>I3</td><td>6</td><td>8</td><td>10</td></tr> <tr><td>Score 2</td><td colspan="3">4</td></tr> </table> <p>Total skor pergelangan tangan = total skor 1 sampai 2 8</p> Dasar Kestabilan <table border="1" style="width: 100%; border-collapse: collapse;"> <tr><th>L1</th><th>L2</th><th>L3</th></tr> <tr><td>K1</td><td>2</td><td>4</td><td>6</td></tr> <tr><td>Total Kestabilan</td><td colspan="3">4</td></tr> </table> Proses Bekerja <table border="1" style="width: 100%; border-collapse: collapse;"> <tr><th>M1</th><th>M2</th><th>M3</th></tr> <tr><td>K1</td><td>2</td><td>4</td><td>6</td></tr> <tr><td>Total Proses Bekerja</td><td colspan="3">4</td></tr> </table> Getaran <table border="1" style="width: 100%; border-collapse: collapse;"> <tr><th>N1</th><th>N2</th><th>N3</th></tr> <tr><td>K1</td><td>2</td><td>4</td><td>6</td></tr> <tr><td>Total Getaran</td><td colspan="3">1</td></tr> </table> Stress Kerja Akibat Keluhan <table border="1" style="width: 100%; border-collapse: collapse;"> <tr><th>O1</th><th>O2</th><th>O3</th><th>O4</th></tr> <tr><td>K1</td><td>2</td><td>4</td><td>6</td><td>8</td></tr> <tr><td>Total stress kerja</td><td colspan="4">1</td></tr> </table>	G1	G2	G3	I1	2	4	6	I2	4	6	8	I3	6	8	10	Score 1	4			K1	K2	K3	I1	2	4	6	I2	4	6	8	I3	6	8	10	Score 2	4			L1	L2	L3	K1	2	4	6	Total Kestabilan	4			M1	M2	M3	K1	2	4	6	Total Proses Bekerja	4			N1	N2	N3	K1	2	4	6	Total Getaran	1			O1	O2	O3	O4	K1	2	4	6	8	Total stress kerja	1			
A1	A2	A3																																																																																																																																																																																																																																																																																																																																																																																																																										
H1	2	4	6																																																																																																																																																																																																																																																																																																																																																																																																																									
H2	4	6	8																																																																																																																																																																																																																																																																																																																																																																																																																									
H3	6	8	10																																																																																																																																																																																																																																																																																																																																																																																																																									
H4	8	10	12																																																																																																																																																																																																																																																																																																																																																																																																																									
Score 1	2																																																																																																																																																																																																																																																																																																																																																																																																																											
A1	A2	A3																																																																																																																																																																																																																																																																																																																																																																																																																										
I1	2	4	6																																																																																																																																																																																																																																																																																																																																																																																																																									
I2	4	6	8																																																																																																																																																																																																																																																																																																																																																																																																																									
I3	6	8	10																																																																																																																																																																																																																																																																																																																																																																																																																									
Score 2	4																																																																																																																																																																																																																																																																																																																																																																																																																											
I1	I2	I3																																																																																																																																																																																																																																																																																																																																																																																																																										
H1	2	4	6																																																																																																																																																																																																																																																																																																																																																																																																																									
H2	4	6	8																																																																																																																																																																																																																																																																																																																																																																																																																									
H3	6	8	10																																																																																																																																																																																																																																																																																																																																																																																																																									
H4	8	10	12																																																																																																																																																																																																																																																																																																																																																																																																																									
Score 3	4																																																																																																																																																																																																																																																																																																																																																																																																																											
B1	B2																																																																																																																																																																																																																																																																																																																																																																																																																											
J1	2	4																																																																																																																																																																																																																																																																																																																																																																																																																										
J2	4	6																																																																																																																																																																																																																																																																																																																																																																																																																										
J3	6	8																																																																																																																																																																																																																																																																																																																																																																																																																										
Score 4	6																																																																																																																																																																																																																																																																																																																																																																																																																											
B3	B4	B5																																																																																																																																																																																																																																																																																																																																																																																																																										
H1	2	4	6																																																																																																																																																																																																																																																																																																																																																																																																																									
H2	4	6	8																																																																																																																																																																																																																																																																																																																																																																																																																									
H3	6	8	10																																																																																																																																																																																																																																																																																																																																																																																																																									
H4	8	10	12																																																																																																																																																																																																																																																																																																																																																																																																																									
Score 5	4																																																																																																																																																																																																																																																																																																																																																																																																																											
B3	B4	B5																																																																																																																																																																																																																																																																																																																																																																																																																										
I1	2	4	6																																																																																																																																																																																																																																																																																																																																																																																																																									
I2	4	6	8																																																																																																																																																																																																																																																																																																																																																																																																																									
I3	6	8	10																																																																																																																																																																																																																																																																																																																																																																																																																									
Score 6	6																																																																																																																																																																																																																																																																																																																																																																																																																											
C1	C2	C3																																																																																																																																																																																																																																																																																																																																																																																																																										
H1	2	4	6																																																																																																																																																																																																																																																																																																																																																																																																																									
H2	4	6	8																																																																																																																																																																																																																																																																																																																																																																																																																									
H3	6	8	10																																																																																																																																																																																																																																																																																																																																																																																																																									
H4	8	10	12																																																																																																																																																																																																																																																																																																																																																																																																																									
Score 1	2																																																																																																																																																																																																																																																																																																																																																																																																																											
C1	C2	C3																																																																																																																																																																																																																																																																																																																																																																																																																										
I1	2	4	6																																																																																																																																																																																																																																																																																																																																																																																																																									
I2	4	6	8																																																																																																																																																																																																																																																																																																																																																																																																																									
I3	6	8	10																																																																																																																																																																																																																																																																																																																																																																																																																									
Score 2	2																																																																																																																																																																																																																																																																																																																																																																																																																											
I1	I2	I3																																																																																																																																																																																																																																																																																																																																																																																																																										
H1	2	4	6																																																																																																																																																																																																																																																																																																																																																																																																																									
H2	4	6	8																																																																																																																																																																																																																																																																																																																																																																																																																									
H3	6	8	10																																																																																																																																																																																																																																																																																																																																																																																																																									
H4	8	10	12																																																																																																																																																																																																																																																																																																																																																																																																																									
Score 3	2																																																																																																																																																																																																																																																																																																																																																																																																																											
D1	D2	D3																																																																																																																																																																																																																																																																																																																																																																																																																										
H1	2	4	6																																																																																																																																																																																																																																																																																																																																																																																																																									
H2	4	6	8																																																																																																																																																																																																																																																																																																																																																																																																																									
H3	6	8	10																																																																																																																																																																																																																																																																																																																																																																																																																									
H4	8	10	12																																																																																																																																																																																																																																																																																																																																																																																																																									
Score 4	6																																																																																																																																																																																																																																																																																																																																																																																																																											
D1	D2	D3																																																																																																																																																																																																																																																																																																																																																																																																																										
I1	2	4	6																																																																																																																																																																																																																																																																																																																																																																																																																									
I2	4	6	8																																																																																																																																																																																																																																																																																																																																																																																																																									
I3	6	8	10																																																																																																																																																																																																																																																																																																																																																																																																																									
Score 5	6																																																																																																																																																																																																																																																																																																																																																																																																																											
F1	F2	F3																																																																																																																																																																																																																																																																																																																																																																																																																										
J1	2	4	6																																																																																																																																																																																																																																																																																																																																																																																																																									
J2	4	6	8																																																																																																																																																																																																																																																																																																																																																																																																																									
J3	6	8	10																																																																																																																																																																																																																																																																																																																																																																																																																									
J4	8	10	12																																																																																																																																																																																																																																																																																																																																																																																																																									
Score 1	6																																																																																																																																																																																																																																																																																																																																																																																																																											
F1	F2	F3																																																																																																																																																																																																																																																																																																																																																																																																																										
I1	2	4	6																																																																																																																																																																																																																																																																																																																																																																																																																									
I2	4	6	8																																																																																																																																																																																																																																																																																																																																																																																																																									
I3	6	8	10																																																																																																																																																																																																																																																																																																																																																																																																																									
Score 2	4																																																																																																																																																																																																																																																																																																																																																																																																																											
I1	I2	I3																																																																																																																																																																																																																																																																																																																																																																																																																										
J1	2	4	6																																																																																																																																																																																																																																																																																																																																																																																																																									
J2	4	6	8																																																																																																																																																																																																																																																																																																																																																																																																																									
J3	6	8	10																																																																																																																																																																																																																																																																																																																																																																																																																									
J4	8	10	12																																																																																																																																																																																																																																																																																																																																																																																																																									
Score 3	4																																																																																																																																																																																																																																																																																																																																																																																																																											
E1	E2																																																																																																																																																																																																																																																																																																																																																																																																																											
J1	2	4																																																																																																																																																																																																																																																																																																																																																																																																																										
J2	4	6																																																																																																																																																																																																																																																																																																																																																																																																																										
J3	6	8																																																																																																																																																																																																																																																																																																																																																																																																																										
J4	8	10																																																																																																																																																																																																																																																																																																																																																																																																																										
Score 4	4																																																																																																																																																																																																																																																																																																																																																																																																																											
E1	E2																																																																																																																																																																																																																																																																																																																																																																																																																											
I1	2	4																																																																																																																																																																																																																																																																																																																																																																																																																										
I2	4	6																																																																																																																																																																																																																																																																																																																																																																																																																										
I3	6	8																																																																																																																																																																																																																																																																																																																																																																																																																										
Score 5	2																																																																																																																																																																																																																																																																																																																																																																																																																											
G1	G2	G3																																																																																																																																																																																																																																																																																																																																																																																																																										
I1	2	4	6																																																																																																																																																																																																																																																																																																																																																																																																																									
I2	4	6	8																																																																																																																																																																																																																																																																																																																																																																																																																									
I3	6	8	10																																																																																																																																																																																																																																																																																																																																																																																																																									
Score 1	4																																																																																																																																																																																																																																																																																																																																																																																																																											
K1	K2	K3																																																																																																																																																																																																																																																																																																																																																																																																																										
I1	2	4	6																																																																																																																																																																																																																																																																																																																																																																																																																									
I2	4	6	8																																																																																																																																																																																																																																																																																																																																																																																																																									
I3	6	8	10																																																																																																																																																																																																																																																																																																																																																																																																																									
Score 2	4																																																																																																																																																																																																																																																																																																																																																																																																																											
L1	L2	L3																																																																																																																																																																																																																																																																																																																																																																																																																										
K1	2	4	6																																																																																																																																																																																																																																																																																																																																																																																																																									
Total Kestabilan	4																																																																																																																																																																																																																																																																																																																																																																																																																											
M1	M2	M3																																																																																																																																																																																																																																																																																																																																																																																																																										
K1	2	4	6																																																																																																																																																																																																																																																																																																																																																																																																																									
Total Proses Bekerja	4																																																																																																																																																																																																																																																																																																																																																																																																																											
N1	N2	N3																																																																																																																																																																																																																																																																																																																																																																																																																										
K1	2	4	6																																																																																																																																																																																																																																																																																																																																																																																																																									
Total Getaran	1																																																																																																																																																																																																																																																																																																																																																																																																																											
O1	O2	O3	O4																																																																																																																																																																																																																																																																																																																																																																																																																									
K1	2	4	6	8																																																																																																																																																																																																																																																																																																																																																																																																																								
Total stress kerja	1																																																																																																																																																																																																																																																																																																																																																																																																																											

Gambar 16 Rekapitulasi Kuisisioner

Rekapitulasi kuisisioner pengamat dan rekapitulasi kuisisioner operator. Ditemukan bahwa pada bagian tubuh punggung mendapatkan skor 20, pada bagian tubuh bahu/lengan mendapatkan skor 18, pada bagian tubuh pergelangan tangan 18, pada bagian tubuh leher mendapatkan skor 8, pada dasar kestabilan beban kerja didapatkan skor 4, pada beban proses kerja mendapatkan nilai skor 4, pada beban proses getaran mendapatka nilai 1, dan pada stress beban kerja mendapatkan skor 1. Jika keseluruhan skor dijumlahkan maka mendapatkan skor 74. Setelah itu akan dihitung untuk mencari skor E.

$$E(\%) = \frac{X}{X_{max}} \times 100\% =$$

$$E(\%) = \frac{74}{176} \times 100\% = 42,04\%$$

Tabel 30 Kategori Skor QEC

QEC score (E)	Aksi
≤ 40%	Bisa Diterima
41-50%	Penyelidikan lebih lanjut
51-70%	Penyelidikan lebih lanjut dan dilakukan perbaikan segera
> 70%	Penyelidikan lebih lanjut dan dilakukan perbaikan sekarang juga

Pada tabel kategori diatas ditemukan bahwa pada proses pengelasan mendapatkan nilai 42,04%, nilai tersebut termasuk dalam kategori resiko menengah dan suatu saat bisa dilakukan penelitian.

7. Perhitungan REBA Akhir
 - a. Operator Mesin Bor



Gambar 17 Postur Kerja Operator Mesin Bor

Pada gambar diatas merupakan usulan postur kerja mesin bor. untuk skoring postur tubuh sebagai berikut.

Tabel 31 Skor Postur Tubuh

Postur tubuh	Skor	Keterangan	Skor akhir
Leher (neck)	1	12° kedepan	1
Batang tubuh (trunk)	1	0°	1
Kaki (legs)	1	Postur Kaki seimbang dan posisi lurus tidak menekuk	1

Tabel diatas merupakan tabel skor untuk masing-masing postur tubuh para pekerja.

Tabel 32 Rekapitulasi Skor REBA

Tabel A	neck												
		1				2				3			
	Legs												
		1	2	3	4	1	2	3	4	1	2	3	4
Trunk	1	1	2	3	4	1	2	3	4	3	4	5	6
	2	2	3	4	5	3	4	5	6	4	5	6	7
	3	2	4	5	6	4	5	6	7	5	6	7	8
	4	3	5	6	7	5	6	7	8	6	7	8	9
	5	4	6	7	8	6	7	8	9	7	8	9	9

Pada perhitungan rekapitulasi skor postur badan tabel A mendapatkan skor 1

Tabel 33 Skor Postur Tubuh

Postur tubuh	Skor	Keterangan	Skor akhir
Lengan Atas (Upper Arm)	1	15° kedepan	1
Lengan Bawah (Lower Arm)	2	104° kedepan	2
Pergelangan Tangan (Wrist)	1	12° ke bawah	1

Tabel diatas merupakan tabel skor untuk masing-masing postur tubuh para pekerja.

Usulan Perbaikan Fasilitas Kerja pada Produksi Parutan Kelapa Berdasarkan...

Tabel 34 Rekapitulasi Skor REBA

Tabel B	Lower Arm						
		1			2		
	Wrist	1	2	3	1	2	3
Upper Arm Skor	1	1	2	2	1	2	3
	2	1	2	3	2	3	4
	3	3	4	5	4	5	5
	4	4	5	5	5	6	7
	5	6	7	8	7	8	8
	6	7	8	8	8	9	9

Pada perhitungan rekapitulasi skor postur badan tabel B mendapatkan skor 1

Tabel 35 Rekapitulasi Skor REBA

Skor A	Tabel C											
	Skor B											
	1	2	3	4	5	6	7	8	9	10	11	12
1	1	1	1	2	3	3	4	5	6	7	7	7
2	1	2	2	3	4	4	5	6	6	7	7	8
3	2	3	3	3	4	5	6	7	7	8	8	8
4	3	3	4	4	5	6	7	8	8	9	9	9
5	4	4	4	5	6	7	8	8	9	9	9	9

Pada tabel diatas didapatkan nilai skor REBA 1 yang didapatkan dari hasil rekapitulasi tabel B yang mendapatkan nilai skor 1 terhadap nilai rekapitulasi tabel A yang mendapatkan nilai skor 1. Dibawah ini merupakan tabel pengkategorian untuk skor REBA.

Tabel 36 Kategori Skor REBA

level aksi	Skor REBA	Level Resiko	Tindakan perbaikan
0	1	Bisa Diabaikan	Tidak Perlu
1	2-3	Rendah	Mungkin Perlu
2	4-7	Sedang	Perlu
3	8-10	Tinggi	Perlu segera
4	11+	Sangat Tinggi	Perlu saat ini juga

Dari perhitungan skor diatas tadi ditemukan nilai 1, yaitu jika dimasukkan pada tabel kategori masuk kedalam kategori resiko rendah dan untuk tindakan bisa diabaikan.

b. Operator Alat Potong Manual

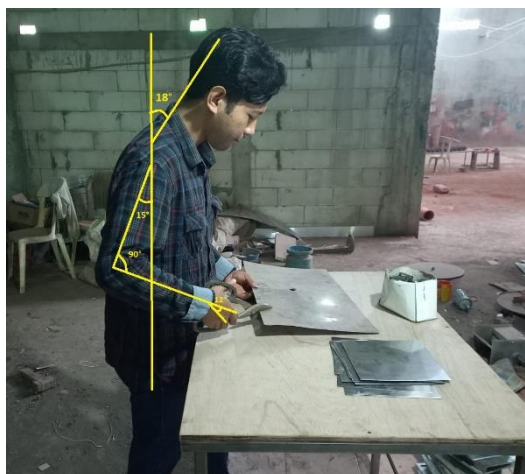

Gambar 18 Postur Kerja Operator Pemotong Manual

Seorang pekerja memiliki sikap kerja seperti gambar diatas, untuk skoring postur tubuh sebagai berikut.

Tabel 37 Skor Postur Tubuh

Postur tubuh	Skor	Keterangan	Skor akhir
Leher (neck)	1	18° kedepan	1
Batang tubuh (trunk)	1	0°	1
Kaki (legs)	1	Postur Kaki seimbang	1

Tabel diatas merupakan tabel skor untuk masing-masing postur tubuh para pekerja.

Tabel 38 Rekapitulasi Skor REBA

Tabel A	neck												
		1				2				3			
	Legs												
		1	2	3	4	1	2	3	4	1	2	3	4
Trunk	1	1	2	3	4	1	2	3	4	3	4	5	6
	2	2	3	4	5	3	4	5	6	4	5	6	7
	3	2	4	5	6	4	5	6	7	5	6	7	8
	4	3	5	6	7	5	6	7	8	6	7	8	9
	5	4	6	7	8	6	7	8	9	7	8	9	9

Pada perhitungan rekapitulasi skor postur badan tabel A mendapatkan skor 1.

Tabel 39 Skor Postur Tubuh

Postur tubuh	Skor	Keterangan	Skor akhir
Lengan Atas (Upper Arm)	1	15° kedepan	1
Lengan Bawah (Lower Arm)	2	90° kedepan	2
Pergelangan Tangan (Wrist)	1	12° keatas	1

Tabel diatas merupakan tabel skor untuk masing-masing postur tubuh para pekerja.

Tabel 40 Rekapitulasi Skor REBA

Tabel B	Lower Arm						
		1			2		
	Wrist	1	2	3	1	2	3
Upper Arm Skor	1	1	2	2	1	2	3
	2	1	2	3	2	3	4
	3	3	4	5	4	5	5
	4	4	5	5	5	6	7
	5	6	7	8	7	8	8
	6	7	8	8	8	9	9

Pada perhitungan rekapitulasi skor postur badan tabel A mendapatkan skor 1.

Usulan Perbaikan Fasilitas Kerja pada Produksi Parutan Kelapa Berdasarkan...

Tabel 41 Rekapitulasi Skor REBA

Skor A	Tabel C											
	Skor B											
	1	2	3	4	5	6	7	8	9	10	11	12
1	1	1	1	2	3	3	4	5	6	7	7	7
2	1	2	2	3	4	4	5	6	6	7	7	8
3	2	3	3	3	4	5	6	7	7	8	8	8
4	3	4	4	4	5	6	7	8	8	9	9	9
5	4	4	4	5	6	7	8	8	9	9	9	9
6	6	6	6	7	8	8	9	9	10	10	10	10

Pada tabel diatas didapatkan nilai skor REBA 1 yang didapatkan dari hasil rekapitulasi tabel B yang mendapatkan nilai skor 1 terhadap nilai rekapitulasi tabel A yang mendapatkan nilai skor 1. Dibawah ini merupakan tabel pengkategorian untuk skor REBA.

Tabel 42 Kategori Skor REBA

level aksi	Skor REBA	Level Resiko	Tindakan perbaikan
0	1	Bisa Diabaikan	Tidak Perlu
1	2-3	Rendah	Mungkin Perlu
2	4-7	Sedang	Perlu
3	8-10	Tinggi	Perlu segera
4	11+	Sangat Tinggi	Perlu saat ini juga

Dari perhitungan skor diatas tadi ditemukan nilai 1, yaitu jika dimasukkan pada tabel kategori masuk kedalam kategori resiko rendah dan untuk tindakan bisa diabaikan.

8. Perbandingan Skor QEC dan REBA Antara Awal-Akhir
 - a. Metode QEC

Tabel 43 Perbandingan Skor QEC Awal dan Akhir

No	Pekerjaan	Sebelum Perbaikan	Sesudah perbaikan	Perubahan
1	Mesin Bor	66,47%	41,14%	38,14%
2	Potong Manual	65,34%	34,65%	46,96%
3	Pengelasan	78,97%	42,04%	46,76%

- b. Metode REBA

Tabel 44 Perbandingan Skor REBA Awal dan Akhir

No	Pekerjaan	Sebelum Perbaikan	Sesudah Perbaikan
1	Mesin Bor	Skor 9, resiko tinggi, dan perlu segera dilakukan perbaikan	Skor 4, resiko sedang, dan tindakan perbaikan perlu
2	Potong Manual	Skor 11, resiko tinggi, dan perlu segera dilakukan perbaikan	Skor 1, resiko sangat rendah, dan bisa diabaikan
3	Pengelasan	Skor 9, resiko tinggi, dan perlu segera dilakukan perbaikan	Skor 3, resiko rendah, dan mungkin perlu dilakukan perbaikan

9. Usulan Perbaikan Untuk Stasiun Kerja Pengelasan

Tabel 45 Usulan Perbaikan Operator Pengelasan

No	Kategori	Usulan	Fasilitas kerja yang diperlukan
----	----------	--------	---------------------------------

1	Penerangan	Ditambahkan penerangan tambahan agar nantinya proses pengelasan bisa dilakukan dengan lebih teliti.	Lampu 40-60 watt
2	Siklus Udara / Tata Udara	Ditambahkan ventilasi agar nantinya oksigen yang ada pada ruang bisa lebih terjaga, kemudian bisa ditambahkan blower atau kipas agar suhu dalam ruang tersebut bisa lebih normal dan tidak terlalu panas yang bisa membuat konsentrasi pekerja menurun, suhu normal dalam ruangan pada siang hari adalah 28° - 30° celcius. Untuk kelembaban udara pada suhu normal ruangan yaitu pada 55% - 66%.	Ventilasi, blower atau kipas
3	Keamanan dan Keselamatan Kerja	Ditambahkan alat pemadam api sebagai upaya untuk penanganan awal jika terjadi kebakaran.	APAR (alat pemadam api ringan)
4	Alat Pelindung Diri	Menyediakan APD pengelasan untuk perlindungan mata dan juga alat pelindung hidung dan mulut agar pekerja bisa lebih terjaga dari asap yang dihasilkan dari proses pengelasan karena sangat berbahaya untuk kesehatan para pekerja.	Helm las, masker hidung

Pada tabel diatas merupakan usulan yang diberikan pada perusahaan untuk memperbaiki fasilitas kerja yang ada pada bagian pengelasan. Pada tabel tersebut berisikan kategori yakni penggolongan usulan kemudian ada usulan dan fasilitas kerja yang diperlukan untuk menunjang usulan yang diberikan.

V. KESIMPULAN

Berdasarkan hasil dari analisis data maka dapat ditarik kesimpulan sebagai berikut :

1. Pada perhitungan metode QEC didapatkan hasil pada mesin bor sebelum perbaikan 66,47% dan sesudah perbaikan menjadi 41,14%. Hasil tersebut mengalami perubahan 53,84% dari hasil perhitungan awal. Pada potong manual sebelum dilakukan perbaikan 65,34% dan sesudah dilakukan perbaikan menjadi 34,65% Hasil tersebut mengalami perubahan 46,96% dari hasil perhitungan awal. Pada pengelasan sebelum dilakukan perbaikan 78,97% dan sesudah dilakukan perbaikan menjadi 42,04%. Hasil tersebut mengalami penurunan 46,76% dari hasil perhitungan awal. Untuk perhitungan yang sudah dilakukan menggunakan metode Rapid Entire Body Assesment (REBA) pada Mesin Bor sebelum dilakukan mendapatkan skor 9 dengan resiko tinggi dan perlu dilakukan perbaikan segera, setelah dilakukan perbaikan skor turun menjadi 4 dengan resiko sedang dan perlu tindakan perbaikan. Pada potong manual sebelum dilakukan mendapatkan skor 11 dengan resiko sangat tinggi dan perlu dilakukan perbaikan saat ini juga, setelah dilakukan perbaikan skor turun menjadi 1 dengan resiko sangat rendah dan perbaikan bisa diabaikan.
2. Dari hasil usulan rancangan fasilitas kerja yang diusulkan untuk UD. Bintang timur hasilnya mampu mengurangi resiko cedera akibat postur kerja yang terjadi pada proses pengeboran, pengelasan, dan pemotongan manual yang sudah dihitung dan dianalisa menggunakan metode Quick Exposure Checklist dan metode Rapid Entire Body Assesment.

REFERENSI

- [1] Hignett, S., & McAtamney, L. (2000). Rapid entire body assessment (REBA). *Applied ergonomics*, 31(2), 201-205.
- [2] Li, G., & Buckle, P. (1999). Current techniques for assessing physical exposure to work-related musculoskeletal risks, with emphasis on posture-based methods. *Ergonomics*, 42(5), 674-695.
- [3] Bridger, R.S. 2003. Introduction to Ergonomics. London : Taylor & Francis.
- [4] National Institute for Occupational Safety and Health (1997) 'Musculoskeletal disorders and workplace factors: A critical review of epidemiologic evidence for work-related musculoskeletal disorders of the neck, upper extremity, and low back. U.S. Dept. of Health and Human Services, Public Health Service, Centers f, (July).
- [5] Norfiza and Zul, I. (2011) 'Perancangan Alat Belajar dan Bermain Yang Ergonomis Di Taman Kanak-Kanak Islam Permata Selat Panjang', *Jurnal Ilmiah Teknik Industri*, 10(1), pp. 48-58.
- [6] Nurmianto, E.2004. Ergonomi Konsep Dasar dan Aplikasinya. Guna Widya. Edisi Pertama. Cetakan Keempat. Surabaya

Usulan Perbaikan Fasilitas Kerja pada Produksi Parutan Kelapa Berdasarkan...

- [7] Purbasari, A. (2019) 'Analisis Postur Kerja Secara Ergonomi Pada Operator Pencetakan Pilar Yang Menimbulkan Risiko Musculoskeletal', *Sigma Teknika*, 2(2), p. 143.
- [8] Tarwaka, Sudiajeng, L. & Bakri, S.H.A. 2004. Ergonomi Untuk Kesehatan dan Keselamatan Kerja dan Produktivitas. Surakarta.UNIBA Press.